

# HUNTLEIGH

## HIGH SENSITIVITY POCKET DOPPLERS

# SERVICE MANUAL

© Huntleigh Healthcare Limited 2004-2009

726374-11



### ***Service Agreements***

***Periodic inspection is essential to ensure continued effective operation. Contact the Company or its approved agents or distributors for further information on service contracts.***

® and ™ are trademarks of Huntleigh Technology Limited

As our policy is one of continuous improvement, we reserve the right to modify designs without prior notice.

**HUNTLEIGH** ...with people in mind

<b>Contents</b>		<b>Page No.</b>
<b>1. General Information</b>		<b>4</b>
1.1	Introduction	4
1.2	Servicing Policy	4
1.3	Description	4
1.4	Antistatic Handling	5
1.5	Construction	5
<b>2. Safety Aspects</b>		<b>6</b>
2.1	Safety	6
2.2	Maintenance / Inspection	6
2.3	Cautions	7
2.4	Care And Cleaning	8
<b>3. Specifications</b>		<b>10</b>
3.1	Safety	10
3.2	Power Supply	10
3.3	Enclosure	10
3.4	LCD Display Elements	11
3.5	Controls	11
3.6	Auto Shut Off	11
3.7	Outputs	12
3.8	Probes	12
<b>4. Technical Description</b>		<b>13</b>
4.1	The Doppler Principle	13
4.2	Doppler Audio Processing	13
4.3	Fetal Heart Rate Processing, (FD2, MD2, FD1, FD3)	13
4.4	Bi-directional Signal Processing (MD2, SD2, RD2)	13
4.5	Probe Identification	14
4.6	Active Noise Reduction	14
4.7	Intelligent Auto Shut Off (FD2, SD2, MD2, FD1, FD3, RD2)	14
4.8	Calibration Pulses	14
4.9	Waveform Conversion	14
4.10	PPG	15
4.11	Data Output	15
4.12	Microcontroller	15
4.13	Standard/Smoothed Mode FHR	15
4.14	Manual Mode FHR	15
4.15	Audio Dopplex (D920, D930), Mini Dopplex (D900)	16
4.16	FD2, SD2, MD2, FD1, FD3, RD2	18
4.17	Obstetric Probe (OP2HS, OP3HS, D920, D930, FD1, FD3)	21
4.18	Vascular Probe (VP4HS, VP5HS, VP8HS, VP10HS, EZ8)	22
4.19	PPG Probe	23
<b>5. Electrostatic Discharge (ESD) Precaution</b>		<b>25</b>
5.1	What Is Static Electricity?	25
5.2	Protective Measures	25
<b>6. Servicing Procedures - Control Unit</b>		<b>26</b>
6.1	Control Unit Dismantling Procedure	26
6.2	PCB Removal	27
6.3	Changing Components	27
6.4	Control Unit Reassembly	28
<b>7. Probe Head Replacement Procedure</b>		<b>32</b>
7.1	Equipment Required	32
7.2	Preparation - For High Sensitivity Probes (OP2HS,OP3HS,VP4HS,VP5HS,VP8HS,VP10HS,EZ8)	32
7.3	Dismantling Procedure - All Probes except D920, D930, FD1 & FD3	33
7.4a	Dismantling Procedure - D920, D930 & FD1	33
7.4b	Dismantling Procedure - D920, D930, FD1 & FD3	34
7.5	New Head Fitting and Alignment	35
7.6	Reassembly Procedure - All Probes except D920, D930, FD1 & FD3	38
7.7a	Reassembly Procedure - D920, D930 & FD1	39
7.7b	Reassembly Procedure - D920, D930, FD1 & FD3	41
7.8	Waterproof Inspection & Test Procedure - D920, D930, FD1 & FD3	43

<b>8. Probe Functional Test Specification</b>	<b>.44</b>
8.1 Equipment Required	.44
8.2 Functional Tests - Vascular Probes VP4HS - VP10HS	.44
8.3 Functional Test - Obstetric Probes OP2HS, OP3HS, D920, D930, FD1 & FD3	.45
<b>9. Fault Finding</b>	<b>.46</b>
9.1 LCD - Marks On Display	.46
9.2 No Sound	.46
9.3 Unit Dead	.46
9.4 No Output From Sockets	.46
9.5 Poor Heart Rate Tracking	.46
9.6 Poor Sensitivity, Crackling	.46
9.7 PPG not locking on	.46
<b>10. Spare Parts list</b>	<b>.47</b>
10.1 D900 Parts List	.47
10.2 D920, D930 Parts List	.49
10.3 MD2, SD2, FD2, FD1, FD3, RD2 Parts List	.51
10.4 Obstetric and Vascular Probe Parts List	.53
10.5 Fixed Waterproof Probes	.54
10.5a D920, D930, FD1 HSB Series Probe Parts List	.55
10.5b D920, D930, FD1, FD3 Probe Parts List	.56
10.6 ISP3 Probe Parts List	.57
<b>11. Ordering Information</b>	<b>.58</b>
11.1 Service Returns	.58
<b>Appendix A</b>	<b>.59</b>
Special Handling Procedures	.59
Recommended Soldering Equipment for Rework	.59
<b>Appendix B</b>	<b>.60</b>
Device History Record Sheet	.60
<b>Appendix C</b>	<b>.61</b>
Recommended Recorder Specifications	.61
<b>Appendix D</b>	<b>.62</b>
Test Equipment Specifications	.62
<b>Appendix E</b>	<b>.63</b>
D920, D930, FD1, FD3 Probe Cable Wiring Details	.63
<b>Appendix F</b>	<b>.64</b>
Waveform Output Connector Details RD2 / MD2	.64
<b>Appendix G</b>	<b>.65</b>
Trace Examples	.65
<b>Appendix H</b>	<b>.66</b>
Electromagnetic Compatibility	.66

# 1. General Information

*Although every care has been taken to ensure that the information in this manual is accurate, continuous development may result in equipment changes. The Company reserves the right to make such changes without prior notification, and resulting manual inaccuracies may occur. This manual and any changes are protected by copyright.*

## 1.1 Introduction

This service manual provides the technical information required for repair and maintenance of the Huntleigh Healthcare Ltd...

- Mini Dopplex - D900
- Audio Dopplex - D920 (with fixed waterproof 2MHz probe), D930 (with fixed waterproof 3MHz probe)
- Fetal Dopplex - FD1 (with fixed waterproof 2MHz probe)
- Fetal Dopplex - FD3 (with fixed waterproof 3MHz probe)
- Fetal Dopplex II - FD2
- Super Dopplex II - SD2
- Multi Dopplex II - MD2
- Rheo Dopplex



... hand held Dopplex range, including the range of OPHS (Obstetric High Sensitivity Probes) and VPHS (Vascular High Sensitivity Probes) interchangeable transducers.

*Please note that the Super Dopplex 1, Multi Dopplex 1 and (NTD) probes are not compatible with the D900, FD2, SD2, MD2, RD2.*

## 1.2 Servicing Policy

Due to the nature of static sensitive surface mount technology, specialised equipment and training is required when working on the surface mounted components used within these products.

For this reason, circuit diagrams are not included in this manual. Block diagrams and fault finding sections are included to make fault finding to leaded component level possible. Units within the warranty period must not be dismantled and should be returned to Huntleigh Healthcare Ltd for repair. Any units returned showing signs of tampering or accidental damage will not be covered under the warranty (refer to user manual for further details).

## 1.3 Description

The Dopplex range of products includes the D920, D930, D900, FD2 (Obstetric Doppler with heart rate display) SD2 (dedicated vascular Doppler), MD2 (Bi-directional vascular Doppler), D920, D930 (Mini Dopplex with waterproof probe), FD1, FD3 (Obstetric Doppler with heart rate display and waterproof probe) and RD2 (vascular Doppler with Photoplethysmographic sensor).

The FD1 and D920 have dedicated 2MHz probes that are hard wired via a retractile cable. The FD3 and D930 have a dedicated 3MHz probe that is hard wired via a retractile cable.

<i>Mini Dopplex (D900 )</i>	is primarily a vascular unit with a non-directional waveform output. The Mini Dopplex accepts the obstetric probes, providing audio only output.
<i>Fetal Dopplex II (FD2)</i>	has interchangeable probes accepting the full range of obstetric and vascular probes, although it is primarily a Fetal Dopplex with a heart rate display. Using the vascular probes, only audio signals are available and there is no rate counting facility, or waveform outputs.
<i>Super Dopplex II (SD2)</i>	is a dedicated vascular Doppler with all the vascular functions of the MD2, but without the RS232 waveform output.
<i>Multi Dopplex II (MD2)</i>	is a multi-purpose Doppler with bi-directional waveform and stereo headphone outputs. Graphical representation of velocity waveforms is given by the LCD display. The same obstetric features of the FD2 are incorporated into the MD2.
<i>Audio Dopplex (D920 D930)</i>	are dedicated obstetric Dopplers with fixed waterproof 2MHz (D920) and 3MHz (D930) probes.
<i>Aqua Dopplex Plus (FD1)</i>	is derived from the FD2, but has a hardwired waterproof 2MHz probe.
<i>FD3</i>	is derived from the FD2, but has a hardwired waterproof 3MHz probe.
<i>Rheo Dopplex II (RD2)</i>	has the vascular functions of the MD2 with the addition of a Photoplethysmographic sensor.

For further details on the controls, please refer to the user manuals.

## 1.4 Antistatic Handling

Due to the nature of the components used within these products, special precautions must be taken to avoid damage to the CMOS and microcontroller based circuitry. Static damage may not be immediately evident but could cause premature failure.

This series of units must only be dismantled and serviced within a specialised handling area (SHA) as defined by CECC00015 (published by CENELEC) to avoid damage to the assemblies.

## 1.5 Construction

The control unit comprises a single PCB on which all circuitry and electro-mechanical components are mounted directly except for the loudspeaker which is attached by flying leads. A hard wired cable provides the connection to the probe.

The PCB has surface mounted components on both sides. All leaded and electro-mechanical components are on one side.

All electro-mechanical and through hole components on the control PCB are serviceable using standard tools and soldering techniques, provided that anti-static precautions are always observed.

The case of the control unit is moulded in ABS polycarbonate alloy, and comprises two halves. The loudspeaker, on/off switch and display are on the front of the unit.

## 2. Safety Aspects

### 2.1 Safety

*The Doppler units and their probes are designed to high standards of performance, reliability and safety.*

*Checks should always be made after carrying out any repairs or dismantling of the equipment.*



Attention, consult accompanying documents / Instructions to Use



Attention consult the Instructions for Use.  
Refer to safety section.

### 2.2 Maintenance / Inspection

Inspection is recommended each time the product is used, paying particular attention to the probe tip, checking for cracks etc., and to the cable and connector. Any crackling or intermittent behaviour should be investigated.

This product does not require periodic maintenance.









For functional testing of specific product features, refer to the user manual.

If you require any assistance with safety testing your Dopplex equipment, contact Huntleigh Healthcare Ltd or your supplier directly.

For the U.K. refer to the Health Equipment Information Document No 95 - Code Of Practice For Acceptance Testing Of Medical Equipment.

The following safety summary should be read before operating or carrying out any of the procedures described in this manual.

## 2.3 Cautions

	Do not use in the sterile field unless additional barrier precautions are taken.
	Do not use in the presence of flammable gases such as anaesthetic agents
	Do Not : <ul style="list-style-type: none"> <li>• immerse in any liquid, (except probe on D920, D930, FD1, FD3)</li> <li>• use solvent cleaner,</li> <li>• use high temperature sterilising processes (such as autoclaving),</li> <li>• use E-beam or gamma radiation sterilisation.</li> </ul>
	Do not dispose of batteries in fire as this can cause them to explode.
	Do not attempt to recharge normal dry-cell batteries. They may leak, cause a fire or even explode.
	This product contains sensitive electronics, therefore, strong radio frequency fields could possibly interfere with it. This will be indicated by unusual sounds from the loudspeaker. We recommend that the source of interference is identified and eliminated.
	Any equipment connected to RS232 interface must be compliant with IEC60601-1:2005.
	Connect headphones only to the headphone socket.









 **WARNING :** *This product is not designed for sterile use. For underwater use where contamination or cross contamination may occur, e.g. during labour and delivery, additional barrier precautions must be taken.*

## 2.4 Care And Cleaning

### General Care

All Huntleigh products have been designed to withstand normal clinical use, however they can contain delicate components, for example the probe tip, which should be handled and treated with care.

Periodically, and whenever the integrity of the system is in doubt, carry out a check of all functions as described in the relevant section of the IFU. If there are any defects to the housing contact Huntleigh or your distributor for repair or to order a replacement.

	Please ensure that you check with your facility's local infection control policy and medical equipment cleaning procedures.
	Observe warnings and guidance on cleaning fluid labelling regarding use and personal protective equipment (PPE).
	Do not use abrasive cloths or cleaners.
	Do not use automatic washers or autoclaves.
	Phenolic detergent based disinfectants, solutions containing cationic surfactants, ammonia based compounds or perfumes and antiseptic solutions such as Steriscol or Hibiscrub should never be used.
	If detergent or disinfectant wipes are used ensure that excess solution is squeezed from the wipe prior to use.
	Do not allow any fluid to enter the products and do not immerse in any solution.
	Always wipe off disinfectant using a cloth dampened with clean water.

**Storage:** If your Dopplex unit is to be stored for a long period of time, the battery should be removed.

**Coupling Gel:** The use of water based gel supplied by Huntleigh Healthcare is strongly recommended. Oil based gels can damage the probe and must not be used. The use of oil based gels will invalidate your warranty.



## General Cleaning and Disinfecting

Always keep the external surfaces clean and free of dirt and fluids using a clean dry cloth.

1. Wipe any fluids from the surface of the product using a clean dry cloth.
2. Wipe with a cloth dampened in 70% Isopropyl Alcohol.
3. Completely dry with a clean, dry lint free cloth.
4. If the product has been contaminated use the methods described for patient applied parts.

## Cleaning and Disinfecting Patient Applied Parts

Clean the probes before examining a patient using low risk cleaning method below.

Following patient examination, clean and/or disinfect the probes by the appropriate method based upon the level of cross contamination risk, as defined below:

Risk	Definition	Procedure
Low	Normal use or low risk situations include patients having intact skin and no known infection and the transducers have not been contaminated with blood	<ol style="list-style-type: none"> <li>1. Remove soiling, wipe with a mild neutral detergent and then wipe with a cloth dampened in water.</li> <li>2. Completely dry with a clean lint free cloth.</li> </ol>
Medium	The patient has a known infection, skin is not intact, the part is heavily soiled, or the patient has given birth in a water bath.	<ol style="list-style-type: none"> <li>1. Follow low risk procedure then wipe with a cloth dampened in Sodium Hypochlorite (1,000ppm).</li> <li>2. After two minutes wipe with a cloth dampened in water and then dry with a clean lint free cloth.</li> </ol>
High	This procedure should only be used when the part has been contaminated by blood.	<ol style="list-style-type: none"> <li>1. Follow low risk procedure then wipe with a cloth dampened in Sodium Hypochlorite (10,000ppm).</li> <li>2. After two minutes wipe with a cloth dampened in water and then dry with a clean lint free cloth.</li> </ol>



*Warning: Sodium Hypochlorite @ 10,000 ppm for disinfecting should only be used in situations described in the High Risk definition. Unnecessary use of this concentrated solution for Low and Medium risk situations may result in damage to the product. Do not allow Sodium Hypochlorite solutions to come into contact with metal parts.*

The use of disinfectant materials other than those listed is the responsibility of the user for their efficacy and compatibility with the device.

## 3. Specifications

### 3.1 Safety

<i>Type of protection against electric shock.</i>	Internally powered equipment.
<i>Degree of protection against electric shock</i>	Type B applied part 
<i>Mode of operation.</i>	Continuous
<i>Degree of protection against water ingress</i>	Hand Unit: IP20 Probes D920, D930 FD1, FD3 : IPX7 All other probes (tip only) : IPX1
<i>Degree of Safety in Presence of Flammable Gases:</i>	Equipment not suitable for use in the presence of a FLAMMABLE ANAESTHETIC MIXTURE WITH AIR, OXYGEN OR NITROUS OXIDE









### 3.2 Power Supply

<i>Battery Type</i>	9 Volt alkaline IEC, 6LR61 or IEC6LP3146.
---------------------	-------------------------------------------

### 3.3 Enclosure

<i>Case Material</i>	Injection moulded ABS Polycarbonate Alloy.
<i>Dimensions (mm) (Height x Width x Depth)</i>	140 x 74 x 27
<i>Weight</i>	295 gms (including probe and battery)

### 3.4 LCD Display Elements

Symbol	Description
	Indicates Standard FHR Mode Selected (FD1, FD3, FD2, MD2 only).
	Indicates Smoothed FHR Mode Selected (FD1, FD3, FD2, MD2 only).
	Indicates Manual FHR Mode Selected (FD1, FD3, FD2, MD2 only).
	Represents Bi-directional blood flow velocity. RD2, in PPG mode indicates size of signal from sensor. (MD2, SD2 and RD2 only).
	Indicates RS232 communication enabled. This flashes when communication is in progress. (FD2, MD2P only).
	Audio/Mini- indicates power on. FD2/SD2/RD2/MD2- indicates power on with probe not connected.
	Indicates battery low and requires replacement.
<b>RT</b>	RT indicates Venous Refilling Time (RD2 only).
<b>Vp</b>	VP indicates Venous Pump Power (RD2 only).
	Shows when blood flow waveforms are inverted (RD2 only).

### 3.5 Controls

On/Off Button	Front panel push-on / push-off
Mode Buttons	Refer to Instructions for Use

### 3.6 Auto Shut Off

<i>FD2, SD2, MD2, FD1, FD3, RD2</i>	3 minute no signal 10 minute unconditional
<i>D900, D920, D930</i>	Fixed 5 minute

### 3.7 Outputs

<i>Audio Output</i>	
<i>Max. Audio Output (Loudspeaker)</i>	500mW rms into 8 $\Omega$ internal speaker
<i>Headphones</i> 	Max. output Power: 25 mW rms (32 $\Omega$ ) Connector: 3.5mm stereo jack socket Max. applied voltage: +9Vdc
<i>D920, D930, D900, FD2, FD1, FD3</i>	3.5mm stereo socket on top panel (mono output).
<i>MD2, RD2, SD2</i>	3.5mm stereo socket on top panel (stereo output).

<i>RS232 Interface</i> 	
<i>FD2, MD2, RD2</i>	Data format: RS232C Connector: 8pin subminiature DIN socket Max. applied voltage: +5Vdc

<i>Waveform Socket</i>	
<i>Non-directional (Mini Dopplex)</i>	3.5mm mono socket. Fixed f/V 0.5V/kHz.
<i>Bi-directional (MD2, RD2)</i>	Sub-miniature 8 pin DIN socket, 3.5V Full scale. Variable f/V depending on gain setting - refer to user manual.

<i>Calibration Signal</i>	
<i>Mini Dopplex</i>	0kHz, 1kHz, 2kHz, 0kHz stepped pulse.
<i>MD2, RD2</i>	Stepped pulse sequence at 0.05% and 0.1% of probe frequency. Zero baseline at start and end of sequence (available on x1 gain setting only).

### 3.8 Probes

<i>D900, FD2, SD2, MD2, RD2 (in addition to PPG)</i>	OP2HS, OP3HS Obstetric Probes VP4HS, VP5HS, VP8HS, VP10HS, EZ8 Vascular Probes
<i>D920, FD1</i>	Fixed 2MHz obstetric waterproof probes.
<i>D930, FD3</i>	Fixed 3MHz obstetric waterproof probes.

## 4. Technical Description

### 4.1 The Doppler Principle

The Dopplex Range all use a technique based on the Doppler principle for non-invasively monitoring movement within the body.

The Doppler principle states that if a signal is transmitted at a fixed frequency and is reflected by a moving body, the frequency of the received signal will be shifted. An increase in frequency results if the reflector is moving towards the transmitter/receiver, and a decrease results if moving away from the transmitter/receiver. The amount of frequency shift is proportional to the velocity of the reflector relative to the transmitter/receiver.

In the Dopplex range, a fixed frequency ultrasonic signal is transmitted from the probe into the body. This is reflected from, for example, moving blood cells. The signal is reflected from these cells and is received by the probe. Due to the movement of the blood cells, a frequency shift results, which is proportional to the blood flow velocity. The Doppler shift is also affected by the angle between the probe and the direction of flow. The Doppler shift frequency is greatest when the flow is directly towards, or away from, the probe.

### 4.2 Doppler Audio Processing

The pocket Dopplex probe contains a transmitter and receiver. The probe sends out a continuous ultrasonic signal (carrier), generated by the piezo-ceramic transmitter crystal, in the frequency range 2 to 10 MHz (depending on probe).

This signal is scattered by blood cells or any other "interface" such as skin, muscle layers, organs, walls of vessels etc. A small proportion of the scattered signal will be reflected back and detected by the receiver.

By demodulating the received signal (removing the high frequency carrier) the Doppler shifted component (i.e. the difference between the transmitted and received signals) can be produced. With typical target velocities found in the human body, this Doppler shift signal falls within the audio frequency range. It can therefore simply be amplified and heard through a loudspeaker. It is important to remember that the sound you hear is an artificial sound, the frequency (pitch) of which is proportional to the velocity of the moving target. It is not the real sound made by blood rushing through an artery or vein, or movement of the fetal heart.

### 4.3 Fetal Heart Rate Processing, (FD2, MD2, FD1, FD3)

In addition to providing this Doppler sound, the circuitry in the FHR signal conditioning section generates an amplitude envelope of the Doppler audio signal. Using auto-correlation, this signal is further processed by the microcontroller to calculate FHR.

### 4.4 Bi-directional Signal Processing (MD2, SD2, RD2)

To achieve bi-directional flow indication, the Doppler signal must be further processed to separate forward and reverse components.

Components of the Doppler signal produced by positive frequency shift represent flow towards the probe, referred to as forward flow. Components of the Doppler signal produced by negative frequency shift represent flow away from the probe, referred to as reverse flow.

The circuitry achieves this separation in the vascular signal processing section producing two frequency envelopes using zero crosser techniques. This signal is presented at the waveform output (MD2, RD2).

The microcontroller also receives these bi-directional signals and displays them on the LCD bargraph to give a visual indication of blood flow velocity and direction.

#### 4.5 Probe Identification

Probe identification is utilised on the D900, FD2, SD2, MD2 and RD2 Doppler units. This is to allow the control unit to identify which probe has been fitted. Fitting an obstetric probe will disable the waveform output(s).

The FD2/SD2/MD2/RD2, with an obstetric probe connected, will display the probe frequency whenever the probe is changed.

The FD2/SD2/MD2/RD2, with a vascular probe connected, will give a continuous indication of probe frequency.

In the SD2, MD2 and RD2 the frequency to voltage conversion factor is changed according to the frequency of the connected probe and the gain setting, effectively rescaling the output.

#### 4.6 Active Noise Reduction

Active noise reduction is used to reduce the amount of "hiss" that is present when the probe is not being used. When a signal is below a set level, the cut off point of the low pass filter is lowered effectively reducing the noise level.

When a large signal is detected, the bandwidth is increased to allow the full range of the signal to be heard at the loudspeaker.

#### 4.7 Intelligent Auto Shut Off (FD2, SD2, MD2, FD1, FD3, RD2)

To increase battery life within the FD2, SD2, MD2, FD1, FD3 and RD2 units, the microcontroller will turn the unit off after 3 minutes of no signal. The unit will also switch off after 10 minutes regardless of signal presence. This function is disabled when it is connected to a Printa which is printing in obstetric or vascular mode (not applicable to SD2, FD1 or FD3).

#### 4.8 Calibration Pulses

The calibration pulses for the D900 are of 1KHz and 2kHz irrespective of probe frequency. The MD2 and RD2 will output pulses of 0.05% and 0.1% of the frequency of the connected probe. The MD2 and RD2 have bi-directional calibration pulses to scale both forward and reverse channels. The calibration facility is disabled when using gain settings other than x1.

#### 4.9 Waveform Conversion

The D900 has a fixed waveform conversion factor of 0.5V/kHz, whereas the SD2, MD2 and RD2 have a conversion factor determined by the probe fitted and the gain setting.

The use of a variable conversion factor results in the waveform output presenting a voltage that is essentially constant regardless of the frequency of probe fitted for the same velocity signal.

## 4.10 PPG

The RD2 incorporates a photoplethysmographic sensor which uses a sensitive infra-red sensor to assess, non-invasively, venous incompetency of the lower limb, in response to a calf muscle exercise.

The electronics for the PPG is enclosed within a pod to which the PPG sensor is attached by a lightweight straight cable.

## 4.11 Data Output

The data output feature on the FD2 and MD2 allows fetal heart rate data to be sent to the Dopplex Printa in real time.

The MD2 and RD2 units send fetal heart rate data via the data socket to the Dopplex Printa in real time OR vascular data to the Dopplex Reporter/Dopplex Printa.

The FD2, MD2 and RD2 will flash the data symbol () during information transfer.

The MD2 and RD2 will output bi directional waveform information in an analogue format via the data socket.

## 4.12 Microcontrollers

The D900, D920, D930 units use an 8 bit microcontroller to carry out "house keeping" duties, such as driving the LCD display and auto shut-off timer.

The FD2, SD2, MD2, FD1, FD3 and RD2 have an 8 bit microcontroller that also performs FHR processing (including auto-correlation), controls the data output, probe decoding and waveform generation.

## 4.13 Standard/Smoothed Mode FHR

The FD2 and MD2 can display FHR in Standard or Smoothed mode. Smoothed mode FHR uses 8 beat averaging while Standard mode FHR uses 4 beats averaging.

## 4.14 Manual Mode FHR

The manual mode on the FD2 and MD2 can be used when the heart sound can be heard, but is too weak or noisy for the microcontroller to calculate the heart rate automatically.

In this mode, the Dopplex unit operates as a stop watch calibrated in BPM (beats per minute).

The stop watch is activated by depressing the "Start/Stop" button, 10 heart beats should then be counted and the button released. The display will then show the average heart rate over the last 10 beats.

4.15 Audio Dopplex (D920, D930), Mini Dopplex (D900)

Block Diagram

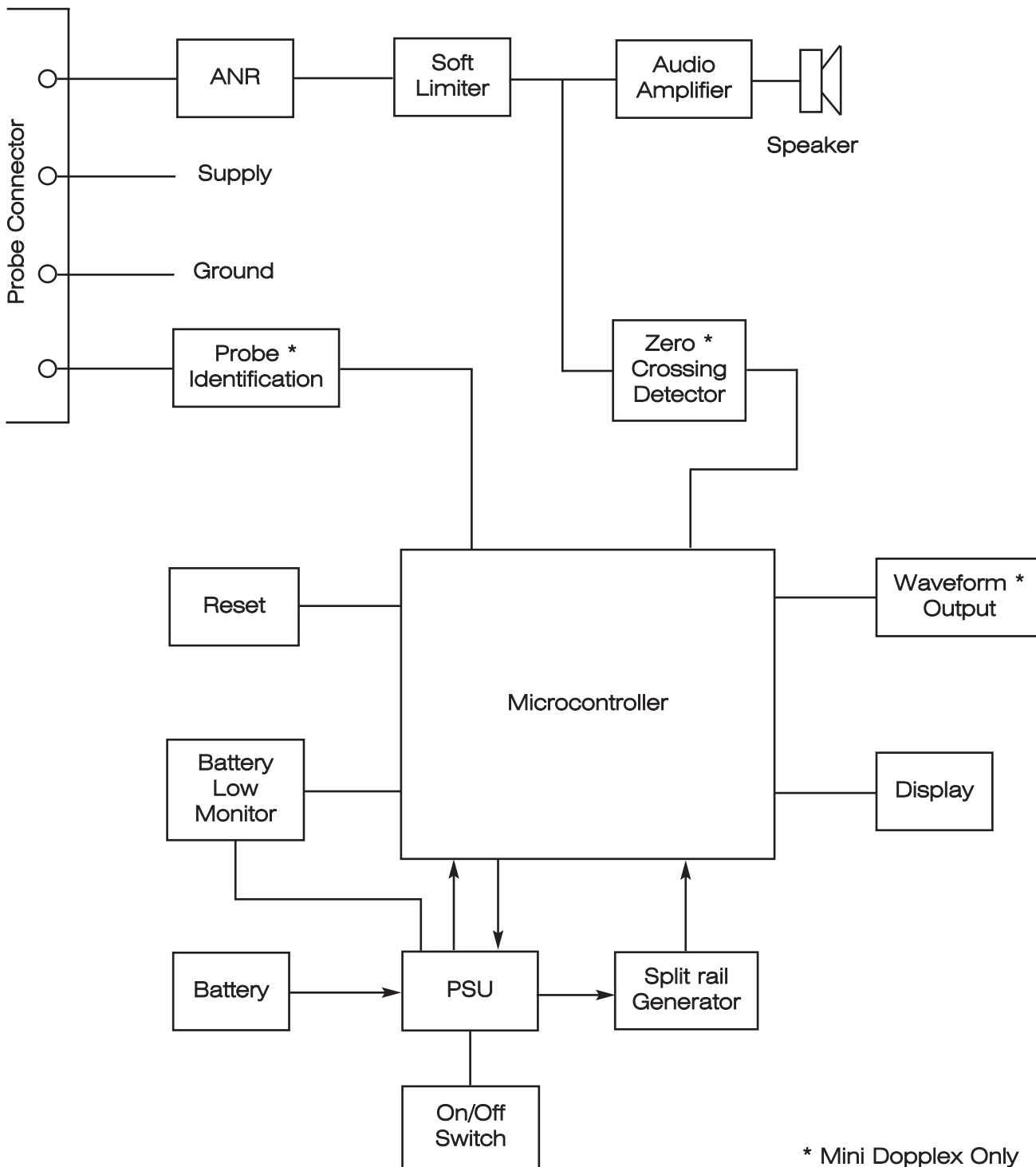

Power Supply

The power supply regulates the battery voltage and provides 5V dc to the microcontroller and all circuitry apart from the audio power amplifier which is supplied directly from the battery. The power supply is activated by the on/off switch. The supply is firstly turned on by the on/off switch and then the microcontroller takes over and keeps the power supply on, turning the supply off when the auto shut off time has elapsed or when the on/off switch is depressed again.



## Power On Reset

Resets the microcontroller whenever the unit is first switched on.

## Probe Identification (D900)

The probe identification feature is used to disable the waveform output whenever an obstetric probe is being used. The probe identification detects the DC level on the output from the probe thus determining the type of probe fitted.

## Battery Monitor

The battery monitor circuit enables the microcontroller to assess the battery voltage by comparing this to a reference voltage.

## Active Noise Reduction (ANR)

Active noise reduction is a technique used to reduce the amount of noise or "hiss" depending on signal level.

When a large signal has been detected the cut off point of the filter is moved so that there is less reduction in high frequency content of the signal. When the signal level is low, or no longer present the filter is switched in to reduce the high frequency hiss.

## Soft Limiter

The soft limiter reduces the level of any harsh overload signals that may occur, for example, when the probe is moved.

## Audio Power Amplifier

The audio power amplifier drives the loudspeaker or headphones. The input level is set by the volume control.

The output signal is fed to the loudspeaker, via the switched headphone socket. On start up there is a delay in the supply of power to the audio amplifier. This allows the circuit to stabilise.

## Zero Crossing Detector (D900)

A zero crossing detector converts the Doppler signal to a corresponding pulse train. This is then fed to the microcontroller which outputs a pulse position modulated signal which is low pass filtered to produce the waveform output voltage.

## Split Rail Generator

The split rail generator is necessary to bias the amplifiers correctly to allow linear operation. The split rail generator supplies a +2.0V dc reference so that the maximum output swing from the amplifiers can be achieved.

4.16 FD2, SD2, MD2, FD1, FD3, RD2

Block Diagram

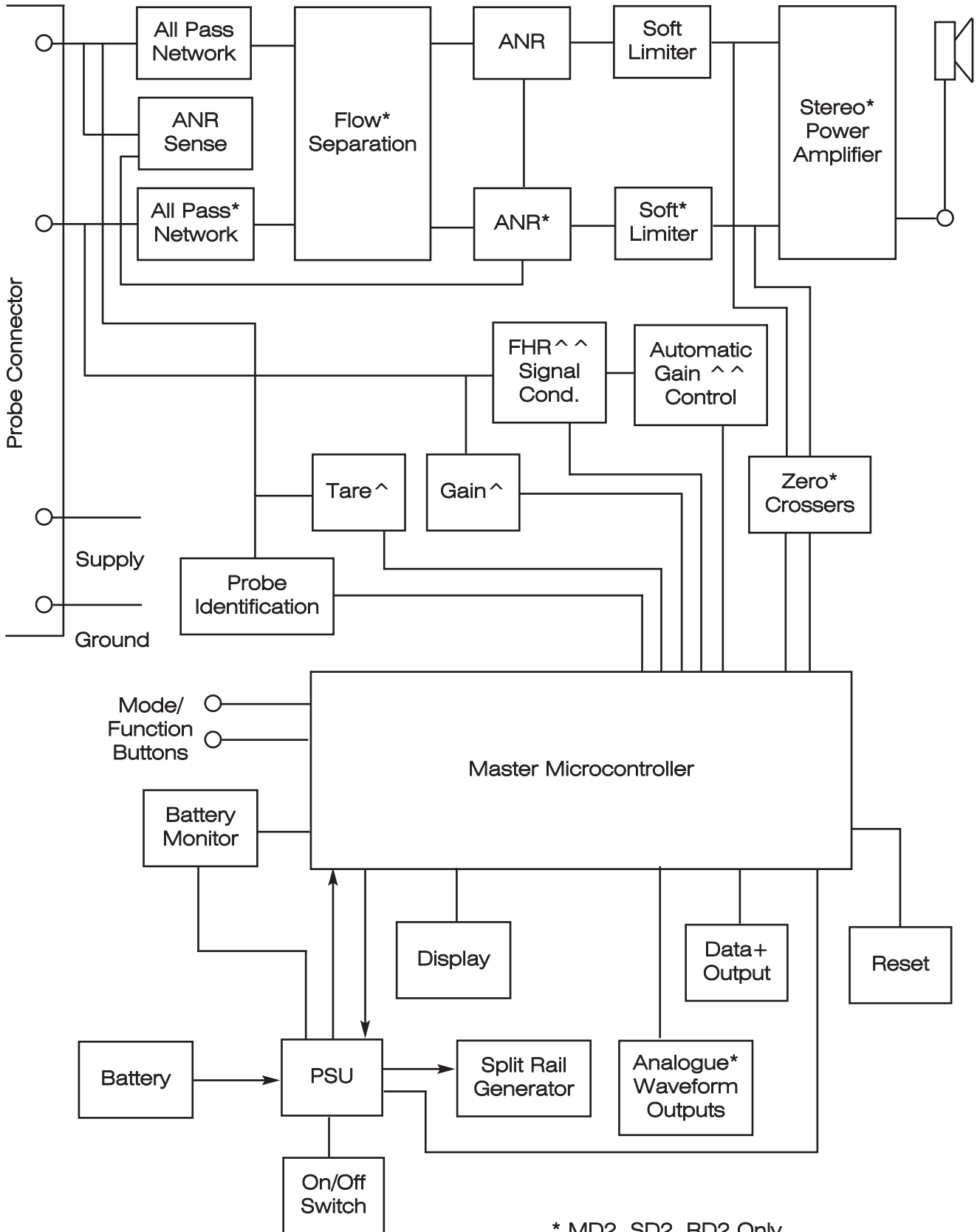

\* MD2, SD2, RD2 Only  
 + Not fitted on SD2, FD1 or FD3  
 ^ Fitted on RD2  
 ^^ Not fitted on RD2, SD2 or FD2

## Power Supply

The power supply regulates the battery voltage and provides +5Vdc to the microcontroller and all circuitry apart from the audio power amplifier which is supplied directly from the battery. The power supply is activated by the on/off switch. The supply is firstly turned on by the on/off switch and then the microcontroller takes over and keeps the power supply on, turning the supply off when the auto shut off time has elapsed or the on/off switch is depressed again.

## Power On Reset

This resets the microcontroller whenever the unit is switched on.

## Probe Identification

The probe identification feature is used to automatically select the operating mode, depending on the probe type and in the SD2, MD2 and RD2, to automatically scale the waveform output. The probe identification circuit detects the DC level on the output from the probe thus determining the type of probe fitted.

## Battery Monitor

The battery monitor circuit enables the microcontroller to assess the battery voltage by comparing this to a reference voltage.

## Active Noise Reduction (ANR)

Active noise reduction is a technique used to reduce the amount of noise or "hiss" depending on signal level.

When a large signal has been detected the cut off point of the filter is moved so that there is less reduction in high frequency content of the signal. When the signal level is low, or no longer present the filter is switched in to reduce the high frequency hiss.

## Active Noise Reduction Sensing

The active noise reduction system relies on the control signal from the sensing circuitry. The filter response is dependent on the control signal level.

## Soft Limiter

The soft limiter reduces the level of any harsh overload signals that may occur, for example, when the probe is moved.

## Audio Power Amplifier

The audio power amplifier drives the loudspeaker or headphones. The input level is set by the volume control.

The output signal is fed to the loudspeaker, via the switched headphone socket. On start up there is a delay in the supply of power to the audio amplifier. This allows the circuit to stabilise.

## Zero Crossing Detector (SD2, MD2, RD2)

Two zero crossing detectors convert the Doppler signals to corresponding pulse trains. The pulse trains are then fed to the microcontroller which converts them to pulse width modulated signals which are then filtered to produce the waveform output voltages.

## Split Rail Generator

The split rail generator is necessary to bias the amplifiers correctly to allow linear operation. The split rail generator supplies a +2.0V dc reference so that the maximum output swing from the amplifiers can be achieved.

## Data Output

The data control IC is an RS232 interface device enabling the microcontroller to communicate with the Dopplex Printa or a computer. The data/waveform socket presents the data from the microcontroller which represents either bi-directional flow waveforms or fetal heart rate, depending on operating mode.

## All Pass Network

The All Pass network is used to apply 90° phase shift to one quadrature probe output signal with respect to the other.

## Flow Separation

The two phase shifted signals are added and subtracted to produce the forward and reverse flow channels.

## Stereo Audio Power Amplifier (SD2, MD2, RD2)

The audio power amplifier provides stereo outputs to the headphone socket. These are combined in the internal loudspeaker.

## FHR Signal Conditioning

The FHR signal conditioning circuit produces an amplitude envelope from which the microcontroller calculates the fetal heart rate when using an obstetric probe.

## Gain control

The gain of the first amplifier of the FHR signal conditioning circuit is increased or decreased by the microcontroller, to regulate the signal level avoiding overloading the following stages.

## Analogue Waveform Outputs

Pulses representing the frequency envelopes of the Doppler signals are output from the microprocessor to two integrating low-pass filters. The two filter outputs are then fed to the analogue waveform/data output socket.

## Gain

A small amount of gain is applied to the incoming PPG signal to ensure that the Microcontroller is functioning at its maximum resolution.

This signal is multiplexed with data relating to the infra red intensity.

## Tare

The Tare line from the Microcontroller is sent to the PPG pod, this will reset the DC level at the output from the probe and start the test.

This signal is also the control line for the multiplexer.

## 4.17 Obstetric Probe (OP2HS, OP3HS, D920, D930, FD1, FD3)

### Block Diagram

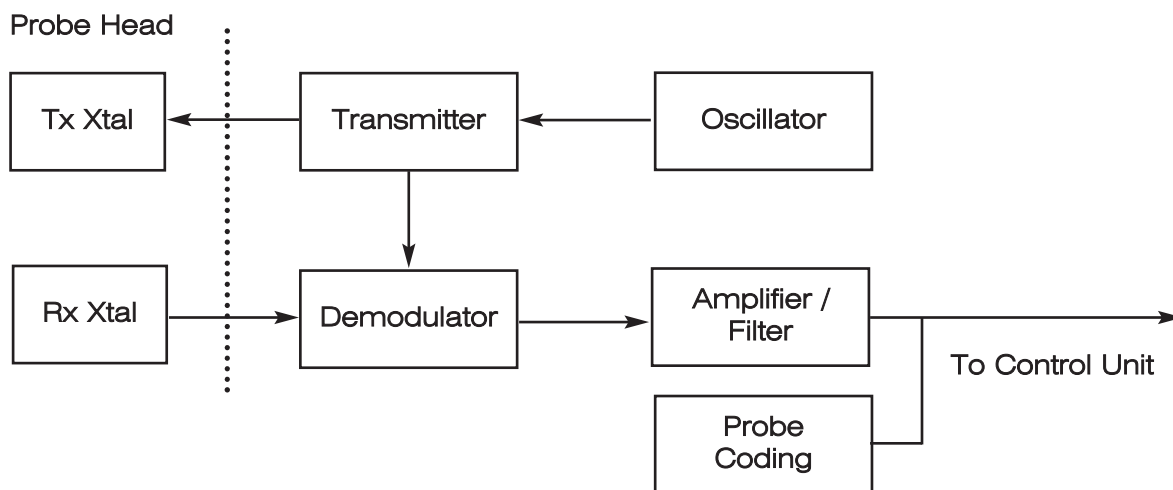

### Oscillator

A ceramic resonator based oscillator circuit provides a reference for the probe receiver and, via the transmitter, the output signal.

### Transmitter

The output from the oscillator is amplified by a single transistor; the gain of this stage is controlled by a variable resistor.

This allows the output voltage to be set according to the impedance of the probe head, thus setting the output power level.

### Demodulator

The demodulator effectively removes the carrier (transmitter frequency), which leaves us with a Doppler shifted signal.

The demodulator stage requires a reference signal from the transmitter stage.

## Amplifier/Filter

The amplifier/filter amplifies the signal from the demodulator stage and removes unwanted noise. The probe has a filter response tailored to maximise the output signal and minimise noise and overload.

## Probe Coding

This superimposes a DC level (depending on probe frequency) onto the output signal.

### 4.18 Vascular Probe (VP4HS, VP5HS, VP8HS, VP10HS, EZ8)

#### Block Diagram

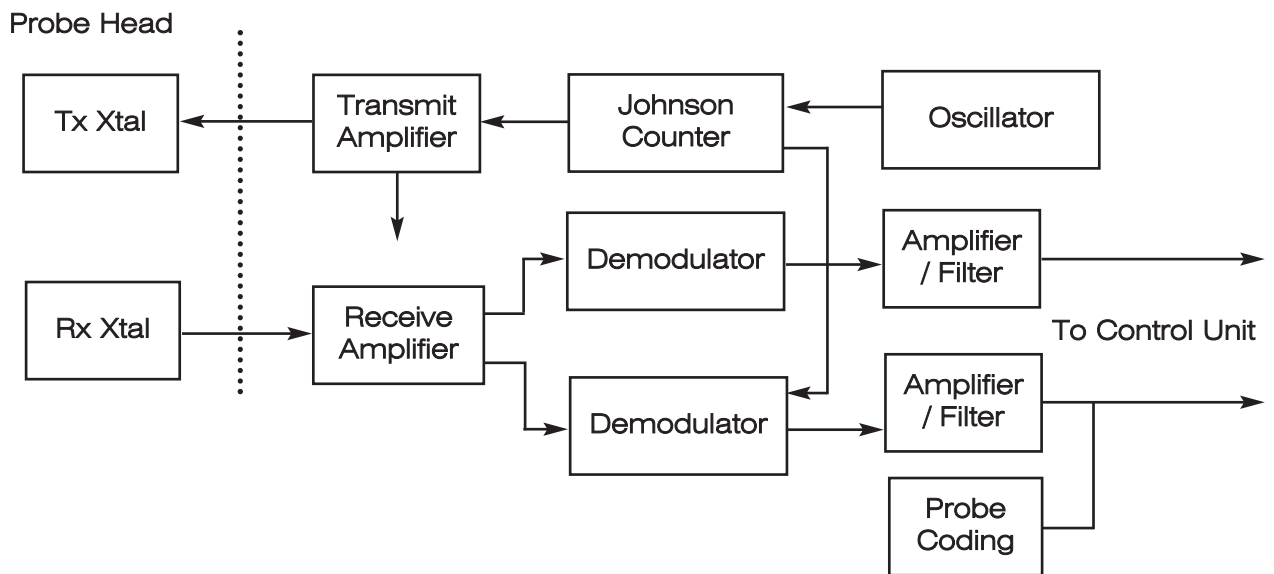

## Oscillator

A crystal oscillator provides references for the probe demodulator and output signal. The oscillator frequency is four times that of the probe ultrasonic output.

## Johnson Counter

The Johnson Counter provides two outputs, which are 90° phase shifted with respect to each other. It also divides the oscillator signal frequency by four.

## Transmitter

The output from the oscillator is amplified by a single transistor; the gain of this stage is controlled by a variable resistor.

This allows the output voltage to be set according to the impedance.

## Receive Amplifier

The received signal is amplified by two FETs (cascode amplifier) providing the demodulators with a suitable signal.

## Demodulators

The demodulators effectively remove the carrier (transmitter frequency), which leaves the Doppler shifted signals.

They have two quadrature reference signals from the Johnson Counter stage.

## Amplifier/Filters

The amplifier/filters amplify the signal from the demodulator stages and remove unwanted noise. Each probe frequency has filters whose response is tailored to maximise the output signal and minimise noise and overload.

## Probe Coding

This superimposes a DC level (depending on probe frequency) onto the output signal.

### 4.19 PPG Probe

#### Block Diagram

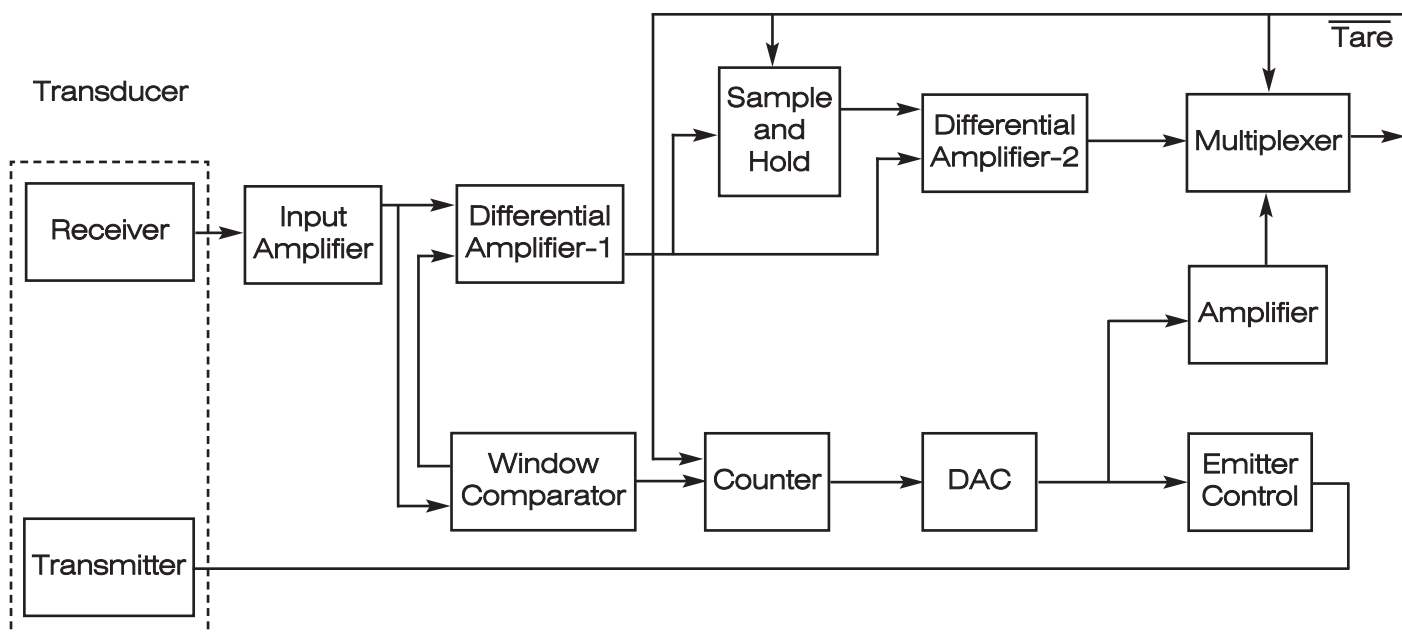

#### Transducer

The Transducer comprises of a transmitter LED and receiver infra-red Photodiodes.

#### Input Amplifier

This provides the necessary biasing from the receiving photodiode and converts the current to a dc voltage.

## Differential Amplifier-1

The differential amplifier is used to remove the majority of the dc offset from the input amplifier. This is necessary as the dc signal from the photodiode is much larger than the change that is to be studied.

## Window Comparator

This monitors the incoming signal and is used to inhibit the clock when the signal is within the ranges preset.

## Counter

The counter provides the DAC with a six bit binary output which increments until inhibited by the Window Comparator.

## Digital to Analogue Convertor (DAC)

The DAC, provides the emitter control circuitry with the necessary drive voltage when the received signal falls within the ranges set by the Window Comparator.

## Emitter Control

This section regulates the drive current to the transmitter LED's and ensures that the drive current is sufficient to set the receive signal within the limits set by the Window Comparator.

## Amplifier

The amplifier allows the multiplexer to operate at maximum resolution, this signal amplified from the DAC allows the RD2 main unit to obtain the LED transmitter intensity.

## Sample and Hold

This circuitry stores the signal from the receive photodiode when selected by the TARE line. The TARE is selected periodically until the received signal stabilises and the test can begin.

## Differential Amplifier -2

The second differential amplifier compares the signal from the sample and hold section with the receiver Photodiode signal and amplifies the difference.

This provides the RD2 via the multiplexer with the change in dc level since the last TARE signal.

## Multiplexer

The multiplexer alternates the output between the LED drive current and signal output.



## 5. Electrostatic Discharge (ESD) Precautions

### 5.1 What is Static Electricity?

Static electricity is generated when two materials move against one another. The voltage generated depends on the materials generating the electricity, the speed of movement, humidity and rate of discharge. All man made materials generate static, such as plastic coffee cups, plastic bags, binders and folders, all of which are likely to be within the working area.

Activity	10-20% Relative Humidity
Walking across carpet	35,000 Volts
Walking across vinyl floor	12,000 Volts
Working at bench	6,000 Volts
Plastic folder	7,000 Volts
Poly bag lifted from bench	20,000 Volts
Foam padded work chair	18,000 Volts

Static electricity is generated very easily, and is only felt by us when we discharge the built up charge rapidly by touching a grounded object such as a door handle. The voltages felt by us are as low as 3kV, but only 20V is necessary to damage some components. Voltages as high as 35kV and current spikes of 40A have been known.

The damage to the component, or assembly can be immediate or latent. Latent damage is not immediately obvious but can lead to the circuitry subsequently failing or becoming erratic.

### 5.2 Protective Measures

Measures must be taken to ensure that all charges generated are safely discharged before they build up to a dangerous level.

The use of dissipative mats for the work surface and wearing anti-static wrist straps are recommended ways of preventing this problem. The dissipative mats must be connected to ground via a resistance and the wrist strap to the same ground point. Anti-static bags must be used when storing or transporting static sensitive components.

Conductive mats are no longer regarded as being suitable, as a PCB or component could be electrostatically charged and it would be rapidly discharged by placing it on the conductive mat. This sudden discharge would be as damaging as placing a charged object in contact with the PCB or device.

All static sensitive devices or assemblies must be placed within an anti-static bag or container whenever being moved away from the specialised handling area.

For further information on static precautions and soldering equipment refer to Appendix A.

## 6. Servicing Procedures - Control Unit

Due to the complexity of the product and the use of surface mount technology, the electronic circuitry is not serviceable without specialised training and equipment. The repairs detailed in this manual are therefore limited to replacement of certain parts in the control unit, and replacement of probe heads only.

Fault finding is limited to checking for the presence or absence of signals around suspect components using an oscilloscope or multimeter.

Repairs should only be undertaken by suitably skilled service personnel.

RD2 probe or sensor is not field serviceable as custom equipment is required during its alignment.



**CAUTIONS:** *This equipment contains static sensitive devices. Refer to Appendix A for recommended anti-static handling precautions. It is essential that these procedures, or equivalent, are adopted to avoid static damage to the circuitry.*

*Due to the high density tracking and small size of components, extreme care in handling the PCB must be taken at all times.*

*When soldering, take care to ensure that the minimum heat is applied to the board and its components for the minimum time necessary to ensure high quality joints. Inspect the area around repairs for solder splashes and bridges. Refer to appendix A for details of recommended soldering techniques.*

### 6.1 Control Unit Dismantling Procedure (see figs 1,2,3)

1. Remove the battery cover by depressing and sliding down and away from the unit.
2. Lift the battery out.
3. Remove the 4 small screws from the rear case half. Do not remove the larger screw in the top centre of the pocket clip.
4. Invert the unit and carefully separate the two case halves by hinging them apart from the base up, freeing the cable grommet from the case as necessary. Pay special attention to the labels on the side and top edges of the unit which adhere to both case halves.

Take care not to damage the locating lugs holding the top of the case halves together.

The PCB is now visible and the following components may be replaced without any further dismantling:

- Loudspeaker assembly
- LCD

## LCD Replacement (FD2, SD2, MD2, FD1, FD3, RD2)

1. Gently lift the display from its socket, noting the location of the orientation mark.
2. Fit the new display taking care to avoid stressing the display or bending the legs.
3. Remove protective film.

## Loudspeaker Replacement

1. Remove the cork gasket from the case front and discard.
2. Remove the foam pad from the case rear and discard.
3. The loudspeaker wires may be unsoldered from the back of the loudspeaker after sliding the sleeving from the terminals. Ensure that the sleeving is replaced on the new loudspeaker terminals.
4. Fit new cork gasket and foam pad.

## 6.2 PCB Removal

1. First remove case halves as previously described.
2. Remove the on/off button and spring from the switch by lifting away.

The PCB is now free to be removed from the case, by pushing the battery terminals from inside the battery compartment. Care should be taken not to damage the top panel label.

The PCB is located on three pillars, each having an "O" ring or washer (see Fig 3) to ensure that the PCB is located correctly. These rings/washers are essential to prevent stressing the board. Take care not to lose them and note their positions for later replacement..

The PCB is now freely accessible allowing replacement of electro-mechanical and leaded components.

## 6.3 Changing Components

After dismantling the control unit as previously described the following repairs can be undertaken.

### Sockets/Switches

1. Carefully de-solder the component using solder wick. Do not use solder pumps as they may generate static.
2. Ease the legs free in the board and lift the socket/switch free taking extreme care not to lift or damage any tracking.
3. Clean the area around the component and fit the replacement.
4. Solder the component taking care not to overheat it or the PCB. Overheating the PCB could result in the tracks breaking.

## Retractable Cable - Control Unit

1. Carefully de-solder the retractable cable using solder wick, leaving the holes clear to fit the new cable (See figures 1,2 and 3).

## Cable Refitting

1. Fit new cable to control unit as described previously.

## Volume Control

1. Carefully de-solder the three electrical connections and two supports using solder wick. Do not use solder pumps as they may generate static.
2. Ease the legs free in the holes and lift the volume control free taking extreme care not to lift or damage any tracking.
3. Clean the area around the volume control and fit the replacement.
4. Solder the volume control taking care not to overheat the volume control or PCB. Overheating the PCB could result in the tracks breaking and the volume control becoming unreliable.

## 6.4 Control Unit Reassembly (see figs 1,2,3)

After dismantling the control unit as previously described the following repairs can be undertaken.

### Sockets/Switches

1. Clean any debris from inside the case halves and carefully wipe the LCD display and the window. This should be done with an anti-static cloth to avoid the build up of static.

Note: When wiped, the LCD display may show marks and symbols when the unit is not turned on. This is caused by static charge on the display and will disappear after a short while.

2. Replace the "O" rings/washers on the PCB mounting pillars referring to the notes made earlier. <sup>0088</sup> Marked products, ensure the 1 copper washer and 2 beryllium washers are fitted as shown in Fig 3.
3. Replace the PCB taking care to ensure that:
  - a) The switches and sockets are correctly engaged in the labels.
  - b) Battery contacts are correctly located in the case.
  - c) No leads are trapped under the PCB.
4. Position the loudspeaker in the PCB cut-out, making sure that the wires are twisted together and are clear of the case halves and switches.
5. Slide the spring over the shaft of the on/off switch button and clip the button on the shaft.
6. Replace the top case half taking care to engage the two locating lugs at the top of the case and to avoid damaging the labels. Ensure that no wires are trapped, that the retractable cable grommet is correctly placed and the On/Off button is located in the cut-out.
7. Check that all labels are secure and undamaged.

8. Replace the 4 fixing screws, and tighten them to a torque setting of 60cNm.

9. Replace battery and access cover.

After any repair work or dismantling, the unit should always be fully tested, checking that all functions operate correctly as described in the user manual.

**Figure 1 D900 Exploded View**

T1	White	Violet
T2	Red	Orange
T3	Black	Pink
T4	Violet	Turquoise
T5	Screen	Screen

Several variations of cable colours are used as shown.

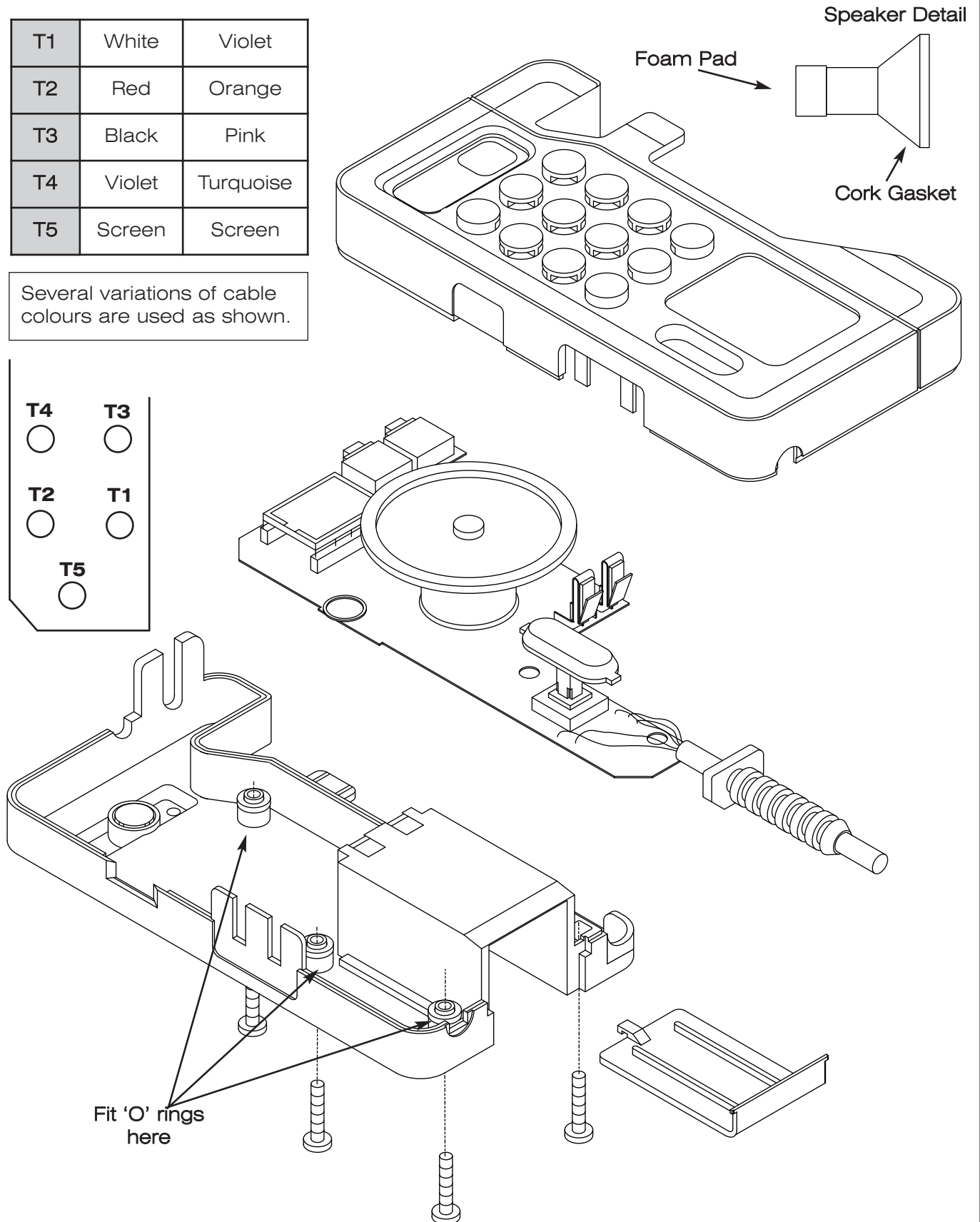
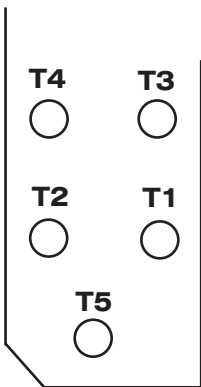
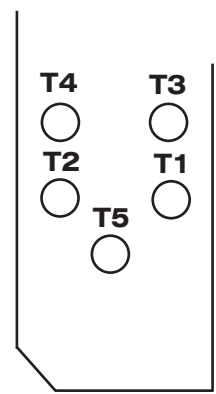
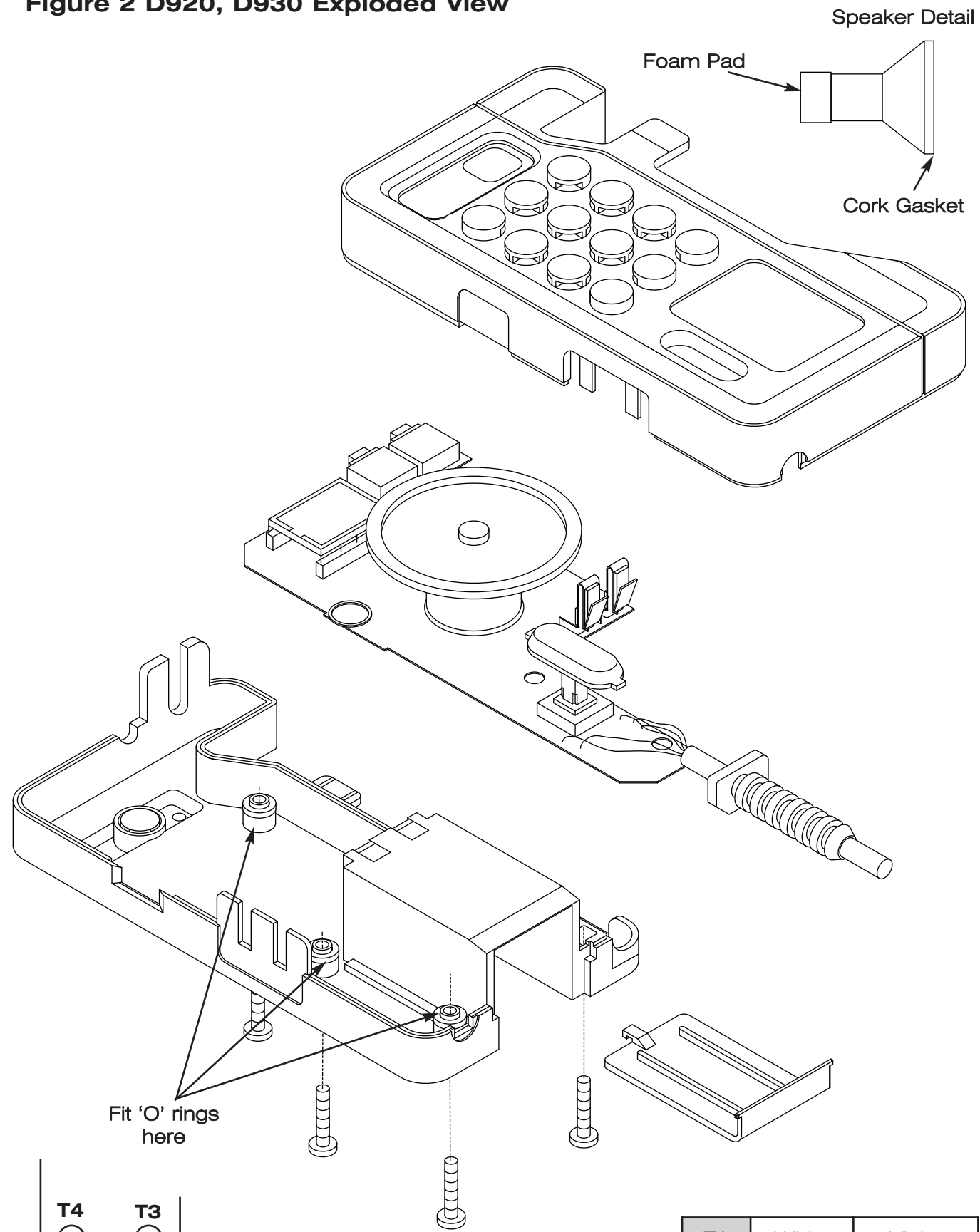

Figure 2 D920, D930 Exploded View



Several variations of cable colours are used as shown.

T1	White	Violet
T2	Red	Orange
T3	Black	Pink
T4	Violet	Turquoise
T5	Screen	Screen

**Figure 3 FD2, SD2, RD2, MD2, FD1, FD3 Exploded View**

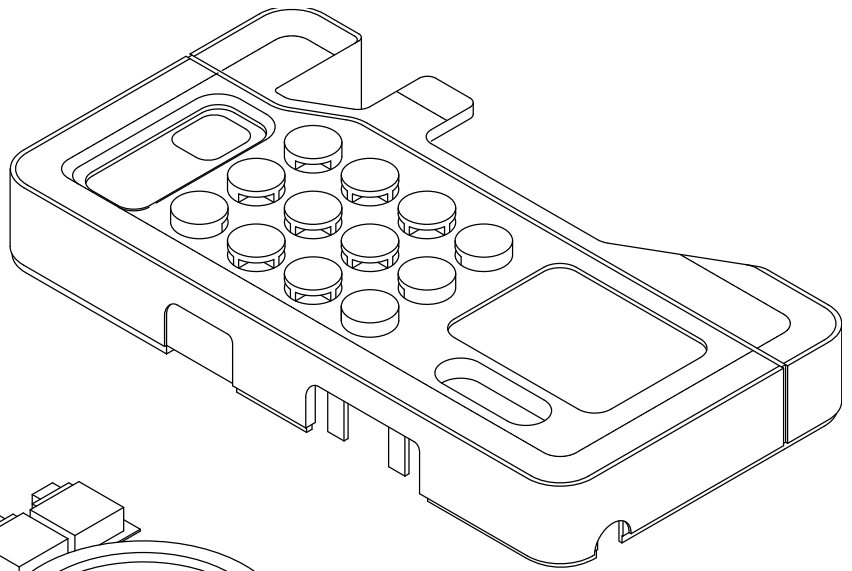
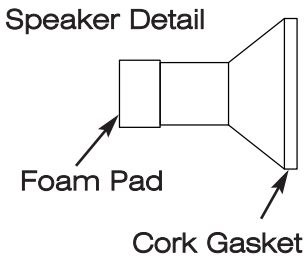
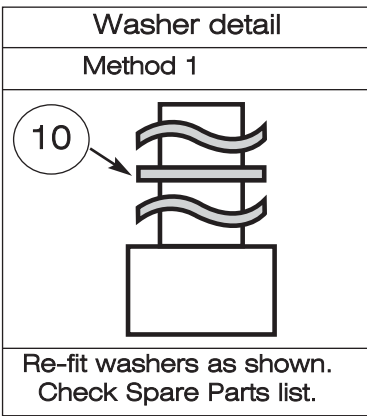

Spring contact details - CE models

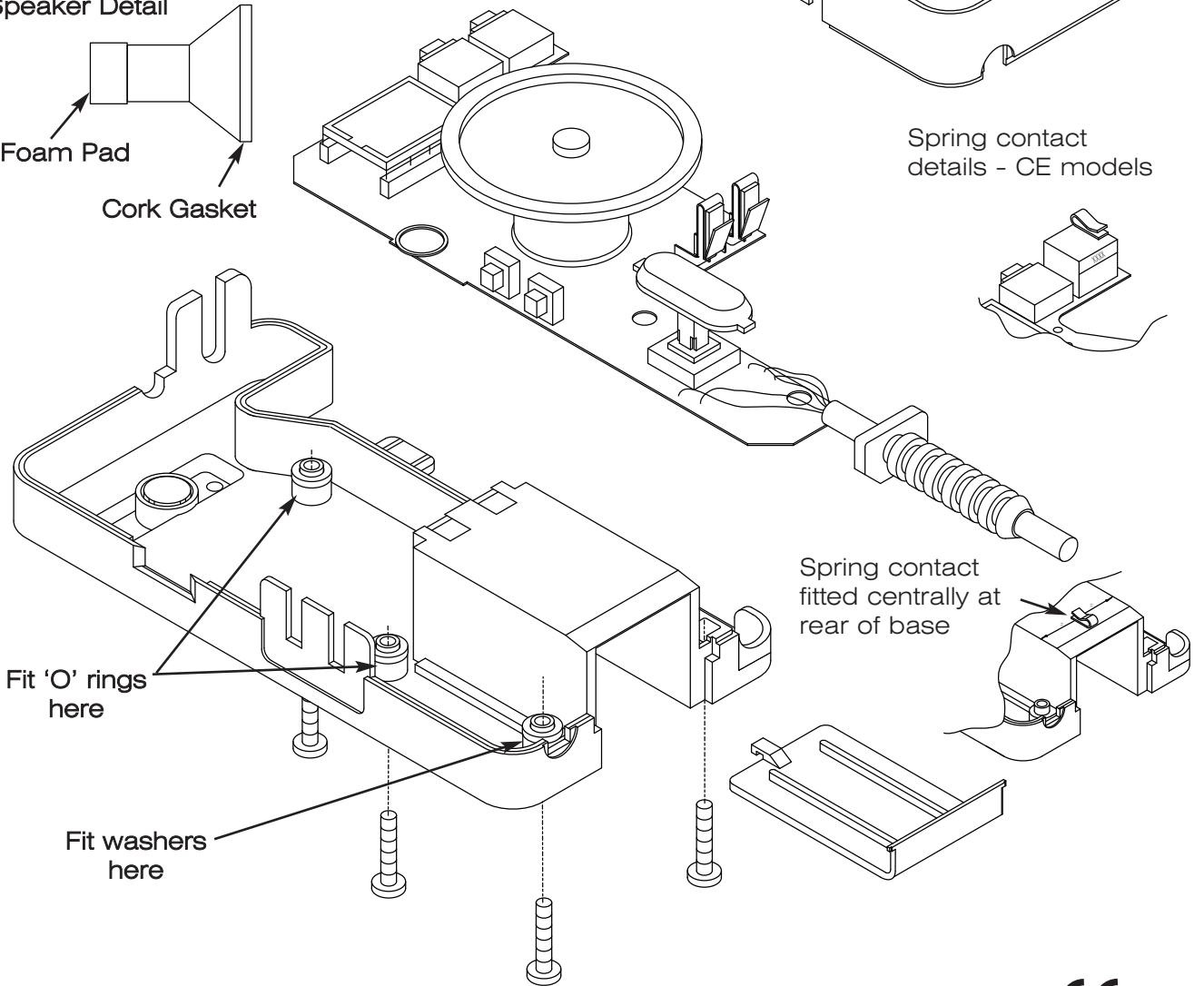
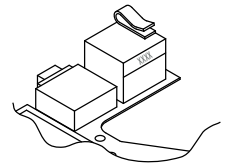

Several variations of cable colours are used as shown.

<b>T4</b>	<b>T3</b>		
○	○	<b>T1</b>	White
			Violet
<b>T2</b>	<b>T1</b>	<b>T2</b>	Red
○	○		Orange
		<b>T3</b>	Black
			Pink
<b>T5</b>		<b>T4</b>	Violet
○			Turquoise
		<b>T5</b>	Screen
			Screen

Check & remove any solder grounding land

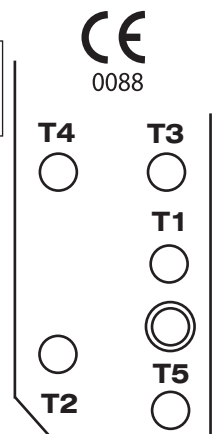

## 7. Probe Head Replacement Procedure

### 7.1 Equipment Required

- Case splitter part number 6AE025 (not required for D920, D930, FD1 & FD3).
- 20MHz Oscilloscope (Gould OS300 or equivalent) and x10 probe.
- Plastic jawed vice.
- DVM on current range (for specification see Appendix D).
- Synthesised signal generator (for specification see Appendix D).
- Head alignment service kit, part number 6AH072.
- Frequency counter (for specification see Appendix D).
- Soldering iron (for specification see Appendix A).
- New case halves, part number 6AE114.
- Power supply (for specification see Appendix D).



#### **SPECIAL HANDLING PROCEDURES**

*The PCB assemblies used in the main unit and probe contain electrostatic device (ESD). These may be permanently damaged by electrostatic potentials encountered in routine handling of the assemblies during servicing.*

*We therefore recommend that all servicing be carried out in a specialised handling area, (SHA) as defined by CECC00015 to avoid damage to the assemblies.*

### 7.2 Preparation - For High Sensitivity Probes OP2HS, OP3HS, VP4HS, VP5HS, VP8HS, VP10HS, EZ8)

The retractile cable must be disconnected from the control unit before head replacement can begin (see section 6.3).

A spare retractile cable or the retractile cable from the unit must be disconnected from the control unit before a head replacement can begin.



### 7.3 Dismantling Procedure - (All probes except D920, D930, FD1 & FD3)

1. Align the case splitter jaws as shown below.

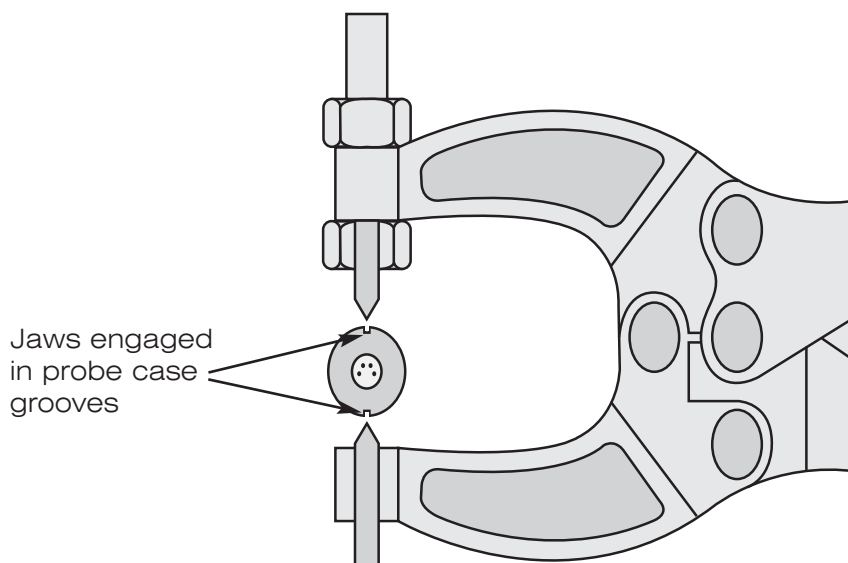

Splitting the Probe Case

2. Gently squeeze the splitter handles together to release the case internal clips.
3. Remove the case splitter and separate the case halves from the probe assembly.
4. Carefully unplug the probe head.
5. De-solder the wire(s) from the screen tube and remove tube.
6. Clamp PCB lightly in vice along its length avoiding stress to the board.

#### 7.4a Dismantling Procedure - D920, D930 & FD1



**Please note:** The retractile cable must be disconnected from the main unit before a head replacement can begin. (See sections 6.1 - 6.3).

1.



Remove the probe clips from the probe with a firm leverage.

Discard clips.

2.

With the clips removed, take off the Head Assy by disconnecting it from the 4 way connector on the Probe PCB.





- 3.** Detach the case moulding from the end cap and slide case moulding over the probe.
- Discard the case moulding.



- 4.** De-solder the wire from the copper screen tube.
- Remove the tube.

Refer to section 7.5 of the head fitting and alignment section of this service manual.

## 7.4b Dismantling Procedure - D920, D930, FD1 & FD3



*Please note: The retractile cable must be disconnected from the main unit before a head replacement can begin. (See sections 6.1 - 6.3).*

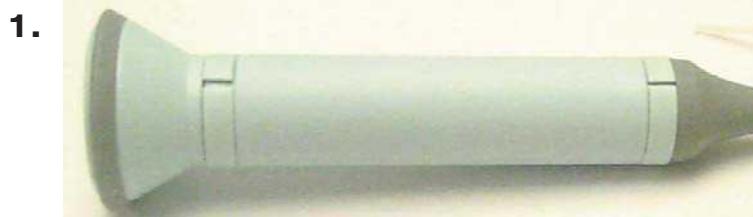

- 1.** Remove the probe clips from the probe with a firm leverage.
- Discard clips.

- 2.** With the clips removed, take off the Head Assy by disconnecting it from the 4 way connector on the Probe PCB.

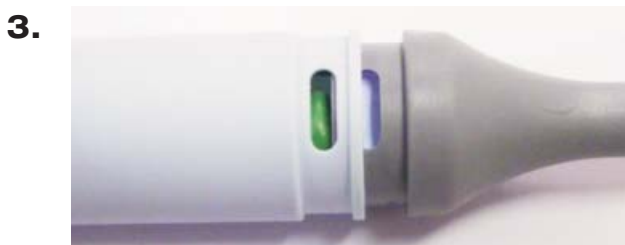
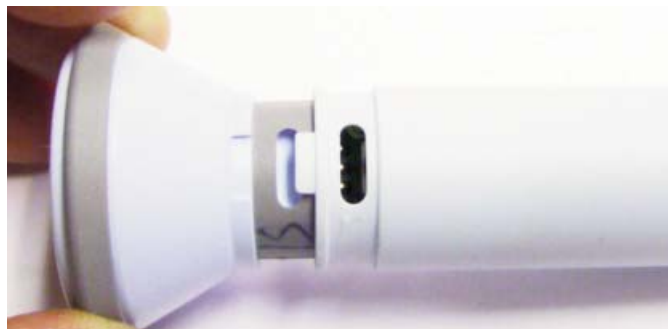

- 3.** Detach the case moulding from the end cap and slide case moulding over the probe.
- Discard the case moulding.

- 4.** De-solder the wire from the copper screen tube.
- Remove the tube.

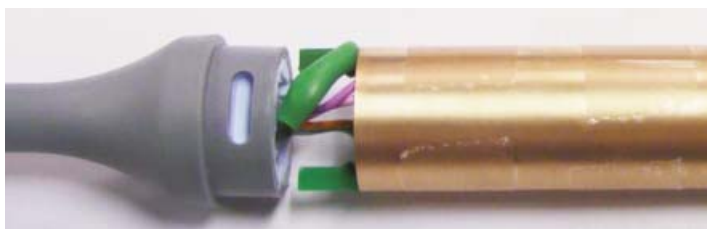

Refer to section 7.5 of the head fitting and alignment section of this service manual.

## 7.5 New Head Fitting and Alignment.

1. Select a new head of correct frequency, identified as shown below.

The probe heads are colour coded on the rear of the head as follows:

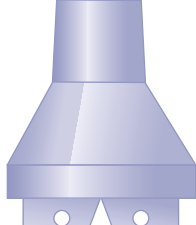
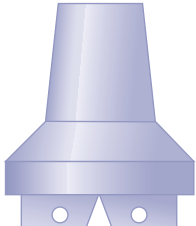
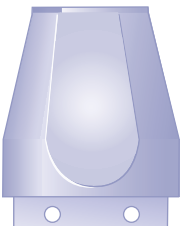
FREQUENCY	HEAD SHAPE	FREQUENCY	HEAD SHAPE
2MHz 3MHz		8MHz 10MHz	
4MHz 5MHz		EZ8	

2. Connect the head adaptor PCB (supplied with head alignment service kit) to the probe. Fit the head to the adaptor PCB as shown below.

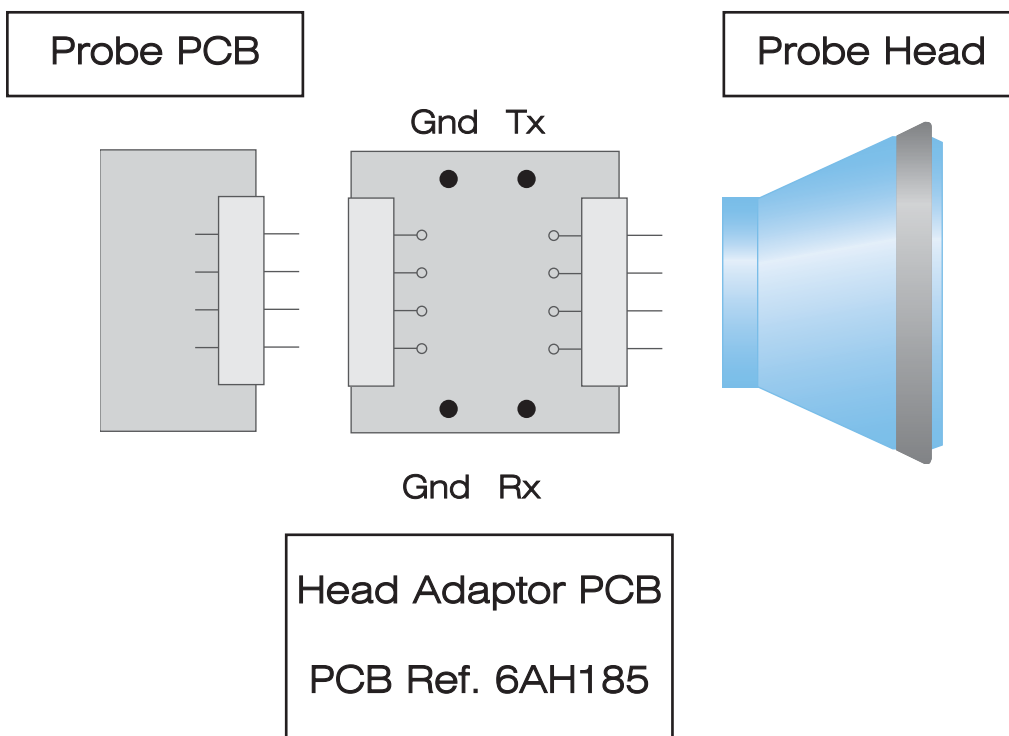

3. Connect the probe in series with the DVM set to measure current and power supply (check that voltage is 5V +/- 1%) as shown below, using power supply adaptor PCB(D920, D930) and adaptor cable (OP/VP probe).

 **CAUTION :** *Incorrect connection will damage probe electronics.*

## Power Supply Wiring

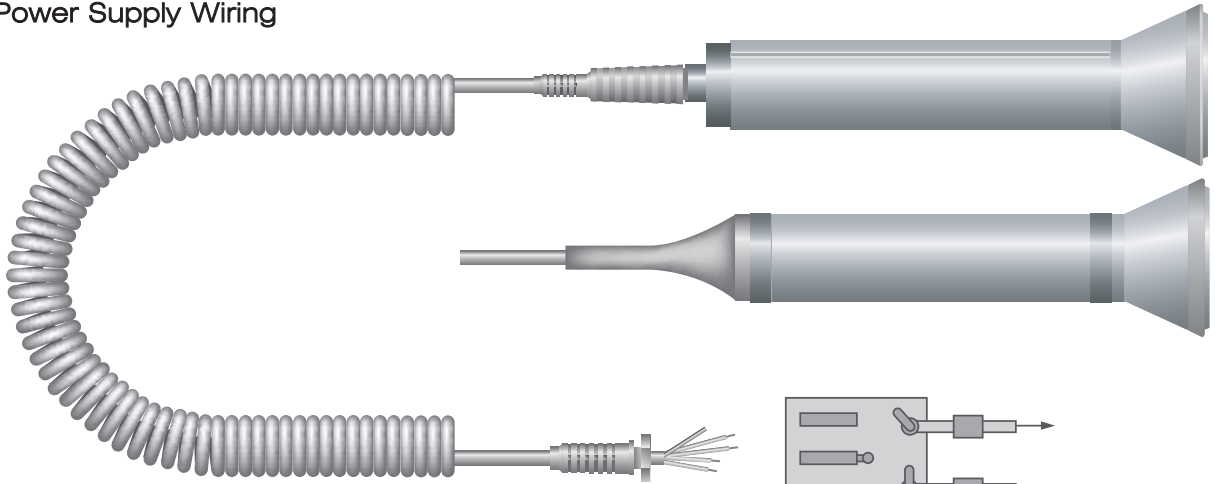

+Ve	Output	-Ve
Red	White	Black/Screen
Orange	Violet	Pink/Screen

Part No.	Description
6AH072	Head Alignment Service Kit

- Switch on power supply.
- Connect scope probe to the Transmitter Terminals (Tx) of the head adaptor PCB and observe Sine wave.
- Adjust PR1 to obtain 1.5V +/- 0.5Vpp (see Figure 3).

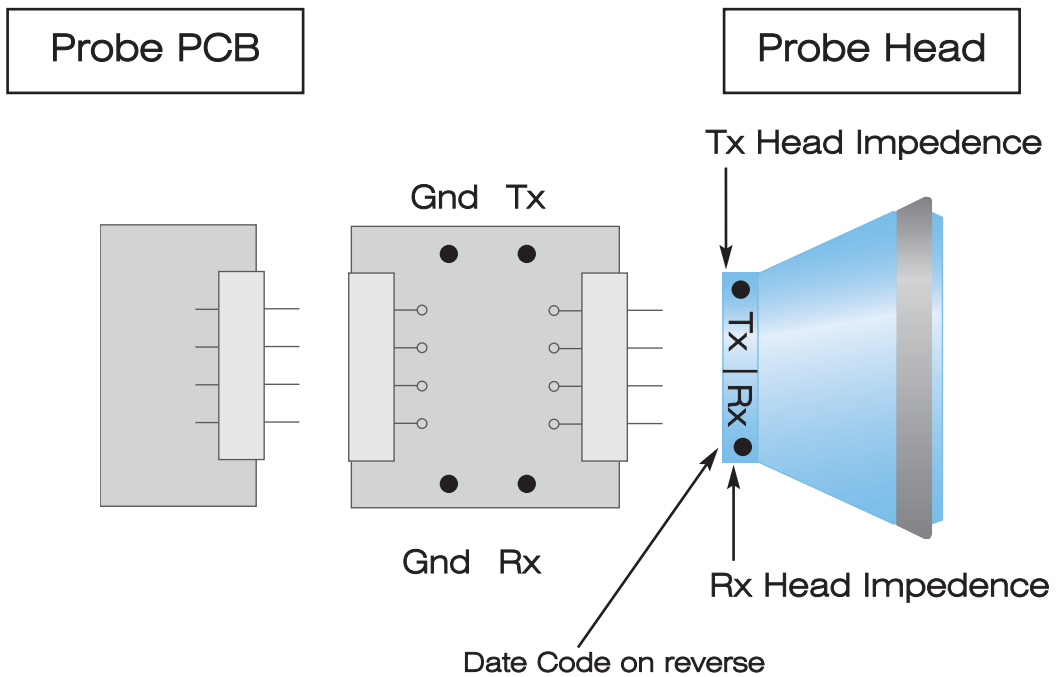

Figure 1 :Obstetric Probe Head Assembly

**Head Adaptor PCB**

PCB Ref.            6AH185  
                             6AH185-B

**Head Adaptor PCB Ref : 6AH185**  
To be used with Head Assemblies:

SP-HEAD - VP4HS  
 SP-HEAD - VP5HS  
 SP-HEAD - VP8HS  
 SP-HEAD - VP10HS  
 SP-HEAD - EZ8HS

SP-HEAD - OP2HSG1  
 SP-HEAD - OP3HSG1

SP-TDR - OP2HSB1  
 SP-HEAD - OP2HSB1

SP-TDR - OP3HSB1  
 SP-HEAD - OP3HSB1

**Head Adaptor PCB Ref : 6AH185-B**  
To be used with Head Assemblies:

SP-HEAD - OP2HSG2  
 SP-HEAD - OP3HSG2

SP-TDR - OP2HSB2  
 SP-HEAD - OP2HSB2

SP-TDR - OP3HSB2  
 SP-HEAD - OP3HSB2

SP-726222 = SP-726219  
 SP-726224 = SP-726218

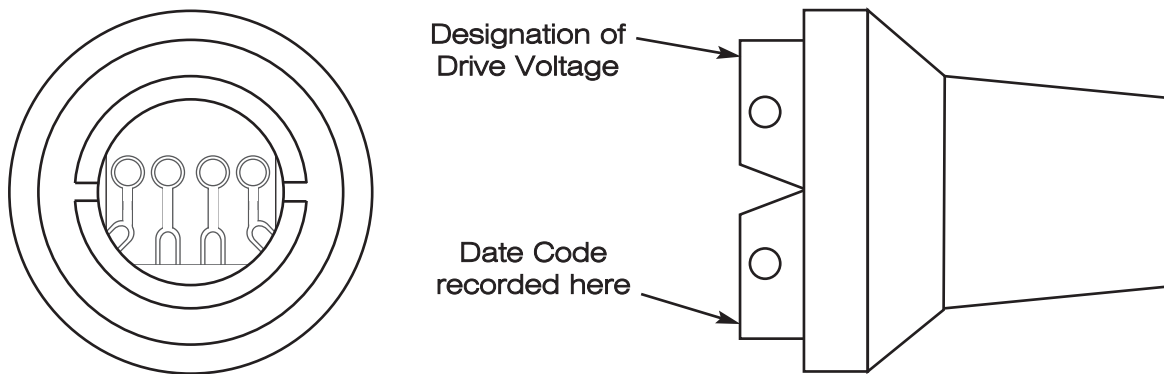

Figure 2 : Vascular Probe Head Assembly

7. Adjust T1 to minimise supply current.

**8a. Vascular Probe Head Assemblies Only [e.g. VP8HS, VP5HS, VP4HS, VP10HS]**

Refer to the Head Assembly to determine drive voltage output for the selected transmitter impedance (see Figure 2.) Set transmitter voltage using PR1(see Figure 3).

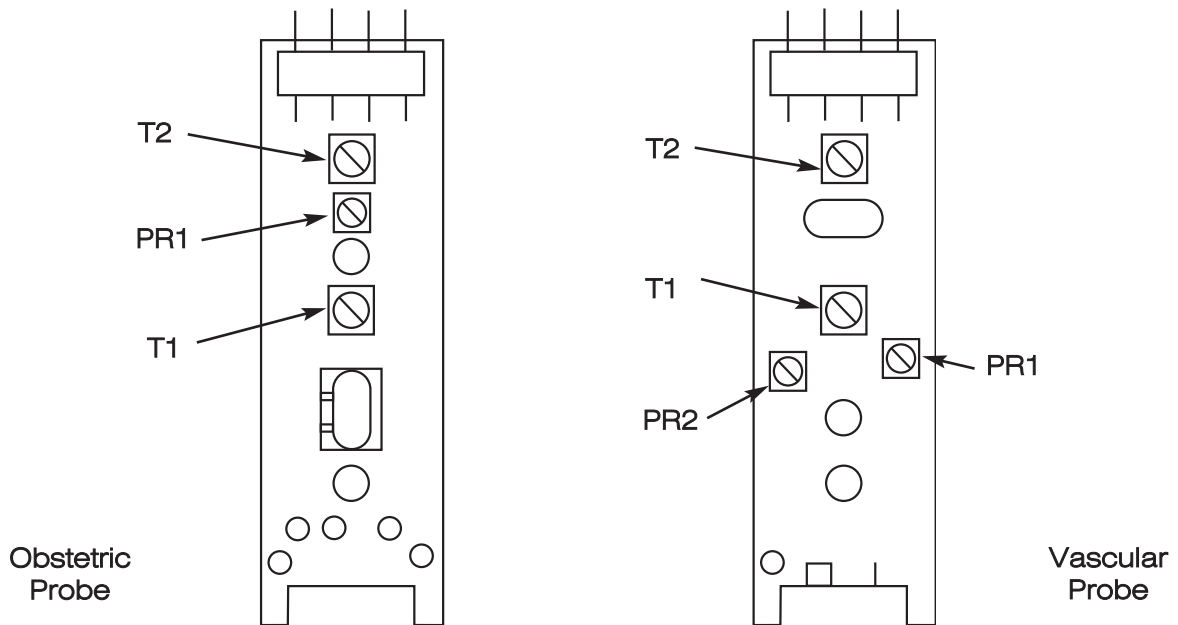

Figure 3 : Probe Layout

### 8b. Obstetric Probe Head Assemblies Only [e.g. OP2HS, OP3HS]

Whilst observing the probe supply current, adjust PR1 so that supply current =  $35_{-0}^{+0.2}$  mA. If 35mA cannot be obtained, set PR1 to maximum current.

- Record this reading on the Device History Record Sheet (Appendix B) along with transmitter impedance and date code.

(e.g. Date "21st June 1993", Product "OP2", Serial Number "135",

Transmitter Head Impedance "24", Drive Voltage "3V", Supply current "35mA", Date Code "TAD").

- Check that supply current is;  
By adjusting T1, < 45mA for VP4, VP5, VP8, VP10, EZ8
- Turn off the power supply and disconnect probe.

## 7.6 Reassembly Procedure - All probes except D920, D930, FD1 & FD3

- Remove the probe head from the PCB if fitted.
- Slide the copper screening tube over the PCB.
- Solder the ground wire(s) to the tube, and tuck the wire(s) into the end(s) of the tube. Fit the head, taking extreme care not to bend the connector pins.
- Fit the new case halves ensuring that the locating lugs align with the holes in the head and end-cap.
- The probe should now be functionally tested, see Section 8.

## 7.7a Reassembly Procedure - D920, D930 & FD1



Please note: Remove the probe head from the PCB if fitted.

1.



Slide the copper screen over the probe and position so that the internal fold is located against the edge of the PCB.

Re-solder in place using tinned copper wire.

2.



Before applying silicon grease to the End Cap, ensure there is no residue of glue left behind from the previous clips.

Ensure locating holes are clean.

Apply silicon grease to the End Cap and inside the case moulding at both ends, using a cotton bud as shown.



*Apply grease to hatched area only. Avoid locating holes of End Cap.*

3.



Slide the case moulding over the probe, ensuring that the holes are fully aligned.

Remove any excess silicon grease with a dry tissue.

4.

Apply silicon grease to the head assembly, as shown by the hatched area.

Ensure that the 4-way connector on the PCB is sitting flush with the board, and that no pins are bent or damaged.



5.



Attach Head Assembly to Probe Assembly.

Ensure that the PCB fits into the slot and the holes are aligned.

*Only use the side of the Head to press down.*

Ensure the pins of the PCB locate into the Head PCB socket.

# Probe Head Replacement Procedure

6. Remove any excess grease from the probe with a dry tissue.

Check that the holes are aligned.



- 7.

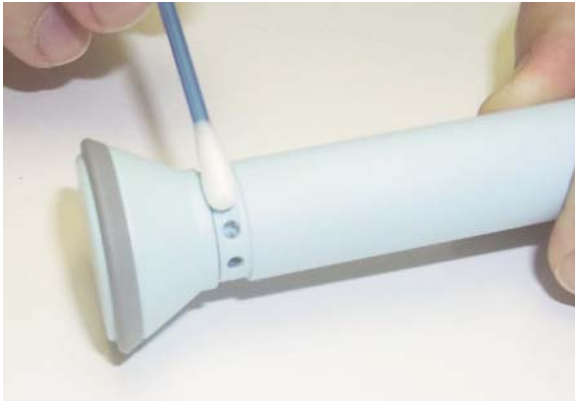

First clean clip recesses at both ends using a dry tissue, then a cotton bud dipped in Propanol.

Allow to fully dry.

*Note: Replacement clips must be cleaned prior to assembly using Propanol, to remove any excess grease.*

8. In the centre of the first recess, apply adhesive\* as a continuous bead of uniform thickness, around the whole circumference of the probe.

Apply a bead of adhesive\* to the 4 holes, then fit clips.

\* Recommended Adhesive : *Loctite 4850*

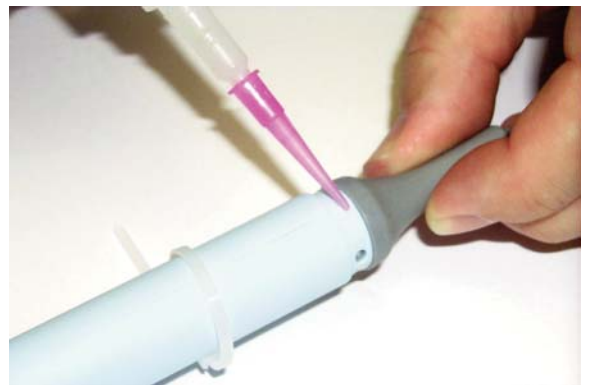

- 9.

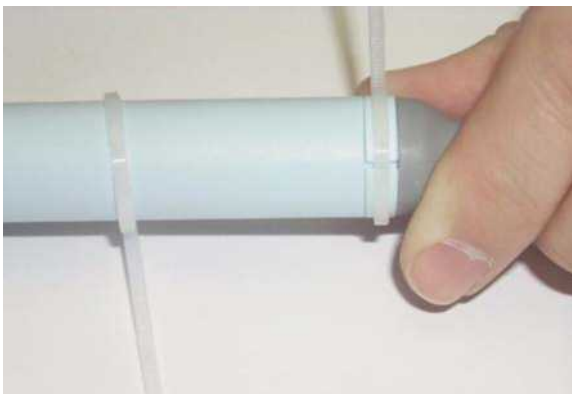

Without delay, fit and tighten the tie wrap around the clips, ensuring that the tie wrap is centrally located.

10. Tighten the tie wrap using a tie wrap gun.  
Repeat at other end.



- 11.

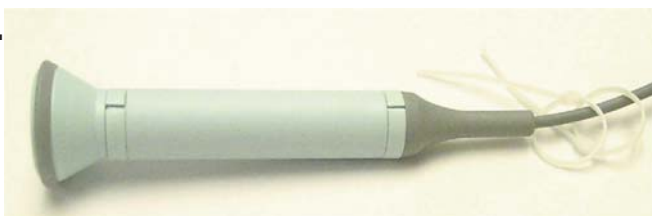

The tie wraps can be removed after 5 minutes by sliding them from the probe body onto the cable, where they can be cut off.



## 7.7b Reassembly Procedure - D920, D930, FD1 & FD3



Please note: Remove the probe head from the PCB if fitted.

1.

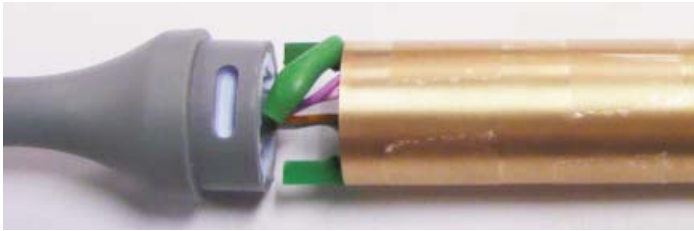

Slide the copper screen over the probe and position so that the internal fold is located against the edge of the PCB.

Re-solder in place using tinned copper wire.

2.

Slide the case moulding over the probe, ensuring that the holes are fully aligned.



3.



Before attaching the Head Assy ensure the 4 way connector on PCB is sitting flush with the PCB, and that no pins are bent.

Slide Head Assy toward the probe assy.

The pins of the PCB on the probe assy must fully locate into the socket on the head assy.

Slide/push the two parts together.

Ensure holes are fully aligned.

4.

Fill both wells at the head end with Silicon.



5.



Insert the clips

6. Snap the clips into place.

Use a clean tissue to remove any excess silicon.



- 7.



Repeat this process at the tail end, ensuring the wells are filled with silicon before inserting the clips.

8. After the clips are snapped into place, use a clean tissue to remove any excess silicon.

Leave the probe for a minimum of 1 hour, to allow the silicon to set.

*The probe must now be waterproof tested.*



## 7.8 Waterproof Inspection & Test Procedure - D920, D930, FD1 & FD3



**IMPORTANT:** This test is only to be carried out with D920, D930, FD1 and FD3 Waterproof probes.

### Equipment Required

1. Sphyg Pressure Indicator (ACC123)

### Waterproof Testing

These tests are designed to ensure the probe is waterproof to an approximate depth of 1.5m of water.

They are done by immersing the probe in water, pressurising it with compressed air, and checking for air leaks.

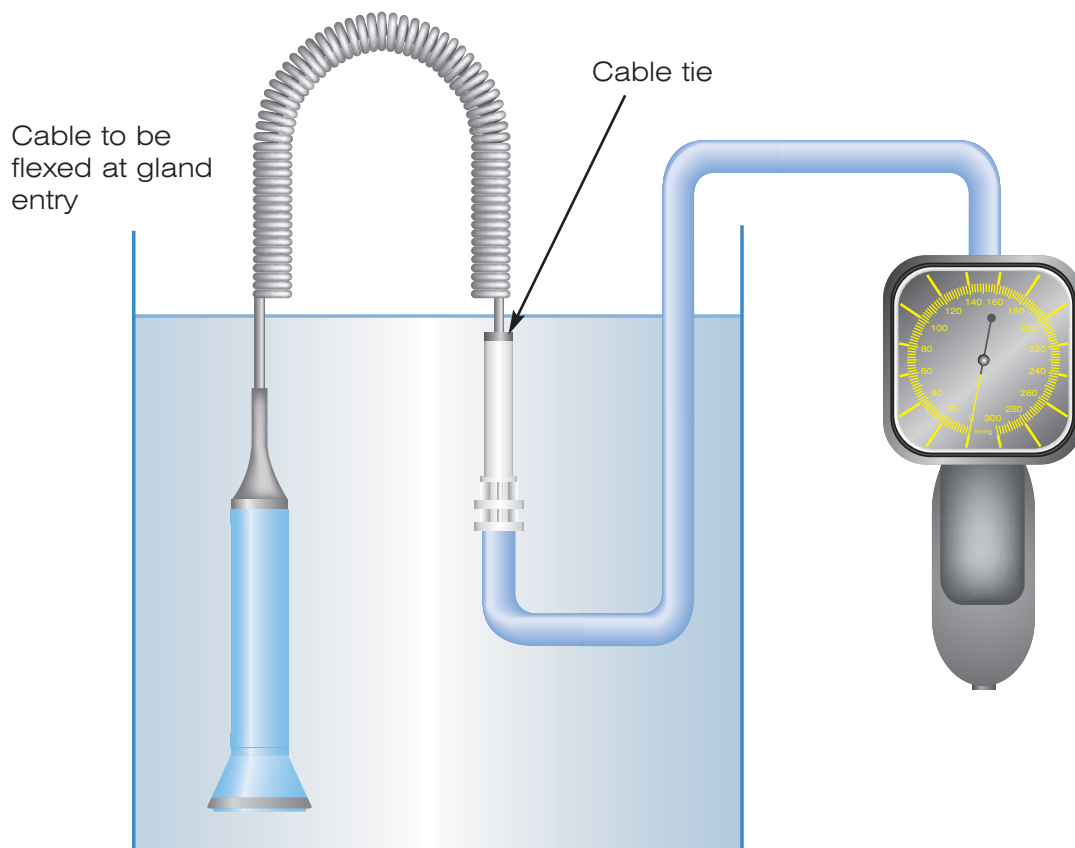

### Probe Test - To test the completed probe

1. Inspect grommet of transducer and peel off any excess silicon from external surfaces before commencing the waterproof test.
2. Adjust the air supply to give 130 +/- 10mmHg.
3. The Probe is pressurised via the cable. Clamp the tube around the cable end using a cable tie. Check the joint to ensure there is no air leak by immersing in water. Flex the cable at gland entry and check for bubbles. If no bubbles are evident, continue test.
4. Check for leaks for a minimum of 30 seconds.
5. *If any air leaks are noted, further investigation is required.*

## 8. Probe Functional Test Specification



**IMPORTANT:** *This test must always be performed after any service work has been undertaken on any probe. Test results should be recorded on Device History Sheet (Appendix B).*

### 8.1 Equipment Required

- Standard MD2 (not required for D920, D930, FD1, FD3).
- Battery 9V alkaline IEC6LR61 or IEC6LP3146
- Chart Recorder (not required for D920, D930, FD1, FD3, OP2HS or OP3HS). Refer to Appendix D for specification.
- Recorder Lead (not required for D920, D930, FD1, FD3, OP2HS or OP3HS). Part number 6AH073.
- Standard Probes as required

### 8.2 Functional Tests - Vascular Probes VP4HS - VP10HS & EZ8

1. Connect the probe to the test unit. Check that the chart recorder lead is plugged into the unit's waveform output socket and that the recorder is switched on.
2. With the unit switched on and with a dry faceplate listen for any RFI (Radio Frequency Interference) whilst handling the probe. This shows up as whines or whistles.
3. Background hiss levels should not be greater than the standard probes.
4. Check for crackling or intermittent audio when probe/retractile are moved.  
  
This may indicate a loose connection.
5. Evaluate the performance level of the probe by testing on the body. Refer to standard probe during test. See figure opposite for recommended probe testing sites.
6. Check that the control unit defaults to bi-directional mode. A probe symbol will be displayed on the right hand side of the screen. Obtain signal and note direction and velocity of blood flow, there should be no or very little cross-talk.
7. Obtain a test trace, refer to examples of traces in Appendix G.

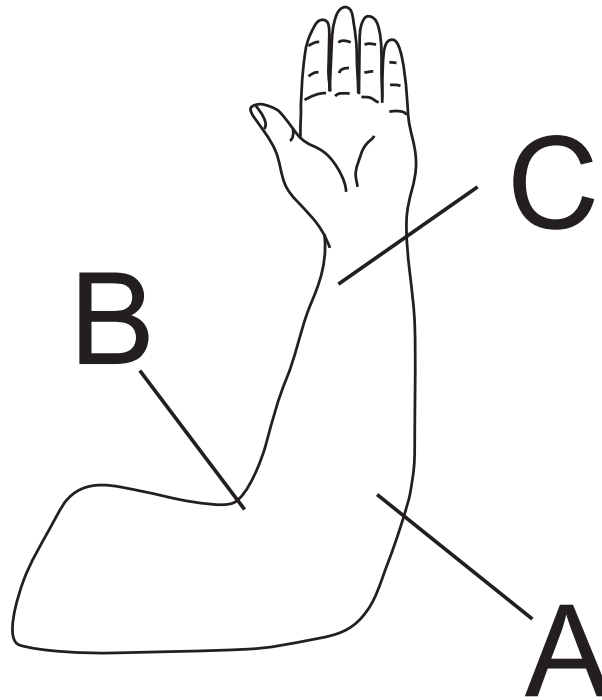

- A. OP2HS, OP3HS, D920, D930, FD1 and FD3 tests on forearm.
- B. VP4HS, VP5HS tests on arm (brachial artery).
- C. VP8HS, VP10HS and EZ8 tests on arm (radial artery).

### 8.3 Functional Test - Obstetric Probes OP2HS, OP3HS, D920, D930, FD1, FD3

*D920P, D930, FD1, FD3*

Switch the unit on. Test the probe for noise and signal levels referring to the figure above for a suitable test site, (using a standard probe as a reference).

*OP2HS, OP3HS*

These must be tested with a MD2 or FD2.

Check that the unit defaults to Fetal Mode, and that the frequency indication is correct. Test audio performance as above.

## 9. Fault Finding

### 9.1 LCD - Marks On Display

1. The LCD display may show marks and symbols when the unit is not turned on. This is caused by static charge on the display and will disappear after a short while.
2. If the marks do not disappear, then the display could be stressed or cracked.

If this is the case fit a new display.

### 9.2 No Sound

1. Check for output at the headset socket. If present, check speaker and headset socket.
2. Check for signal on input to volume control potentiometer and output to headset socket.
3. If no fault is found with the headset socket, volume control or speaker fit a new PCB.

*N.B. Stereo output is only available with the SD2, MD2 or RD2 with headphones connected.*

### 9.3 Unit Dead

1. Check for supply voltage across the on/off switch, if supply is not present it may be a broken track, battery connector or a flat battery.

### 9.4 No Output From Sockets

1. Check integrity and continuity of sockets.
2. Refer to user manual to ensure that the Dopplex is in the correct mode.

### 9.5 Poor Heart Rate Tracking

1. Refer to user manual to ensure that correct technique is used.

### 9.6 Poor Sensitivity, Crackling

Test for cracked crystals as follows:

1. Connect transducer to control unit (not applicable to D920 D930, FD1 or FD3).
2. Set audio volume to maximum. Ensure that faceplate is clean, dry and unmarked.



**CAUTION:** *Under no circumstances should pressure be applied directly to the front face of the probe head or PPG sensor.*

3. Apply firm pressure radially around the outside edge of the faceplate using thumb and forefinger. Listen for clicking, instability or change in background noise level.
4. If any of these effects are heard, reject the probe for head replacement.

### 9.7 PPG not locking on

1. Check retractile cable with either known good PPG probe or vascular probe.

If fault still persists, consult Huntleigh Healthcare Ltd Service Department.

# 10. Spare Parts List

The following spare parts can be ordered from your dealer, or direct from Huntleigh Healthcare Ltd using the part numbers shown below:

## 10.1 D900 Parts List

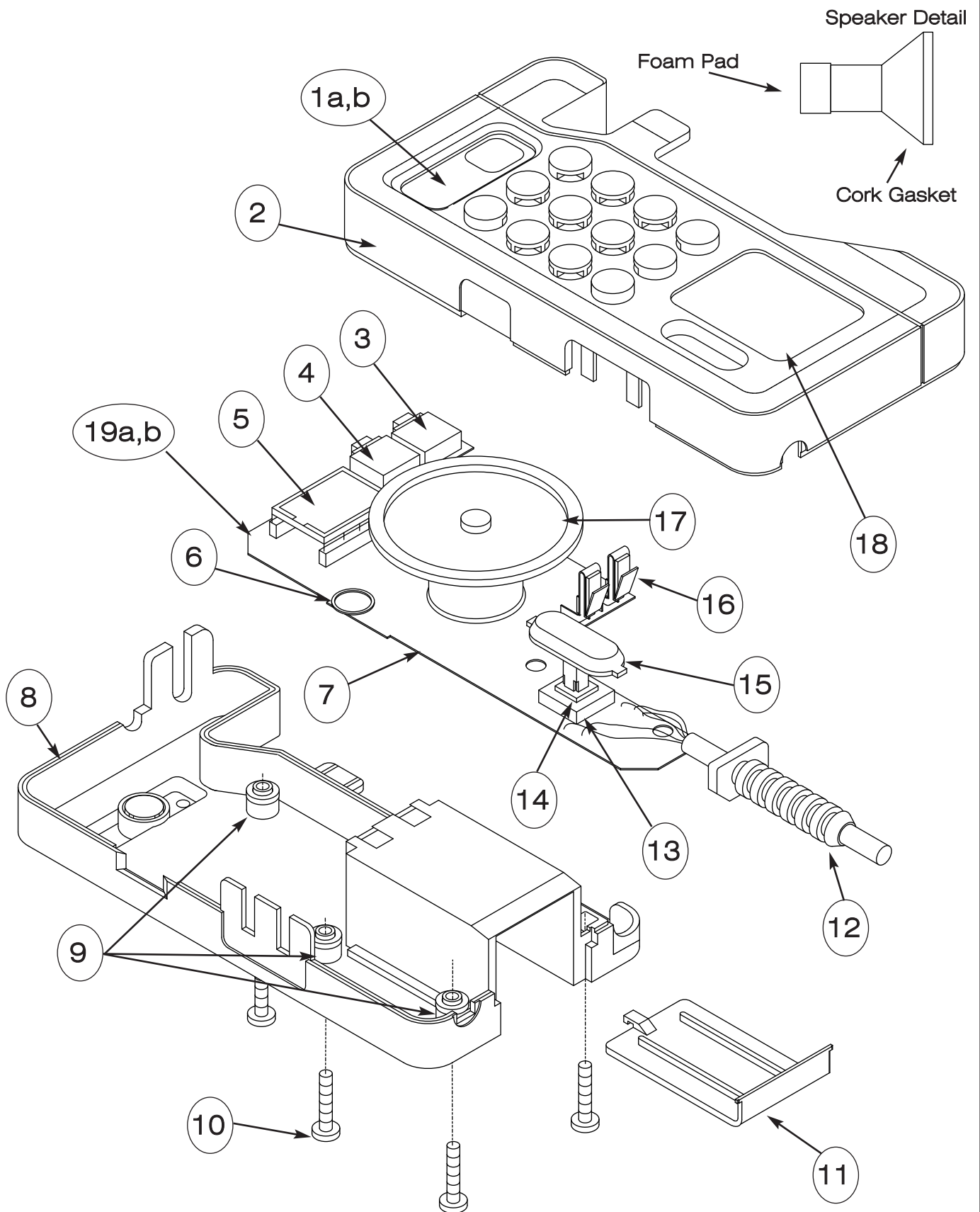

Ref	Part Number	Description
1a	SP-6AH102	Window Label
1b	SP-734303	Window Label (LED Model)
2	SP-6AE102	Case Front
3	SP-726540	Waveform Socket
4	SP-726539	Headphone Socket
5	SP-CS194	LCD Display
6	SP-726487	Volume Control
7	SP-B3F-3150	Calibration Switch
8	SP-6AE103/1	Case Rear
9	SP-200-901	'O' Rings (3 per pack)
10	SP-726544	Case Screw (4 per pack)
11	SP-726486	Battery Cover
12	SP-6AH104	Retractable Cable
13	SP-B3W-4050	On/Off Switch
14	SP-6AE171	On/Off Button Spring
15	SP-726335P	On/Off Button
16	SP-726485	Battery Terminal (2 per pack)
17	SP-770312	MD Family Loudspeaker Assembly
18	SP-726308	Label Set
19a	SP-726069	D900 PCB
19b	SP-734053	D900 PCB (LED Model)



## 10.2 D920, D930 Parts List

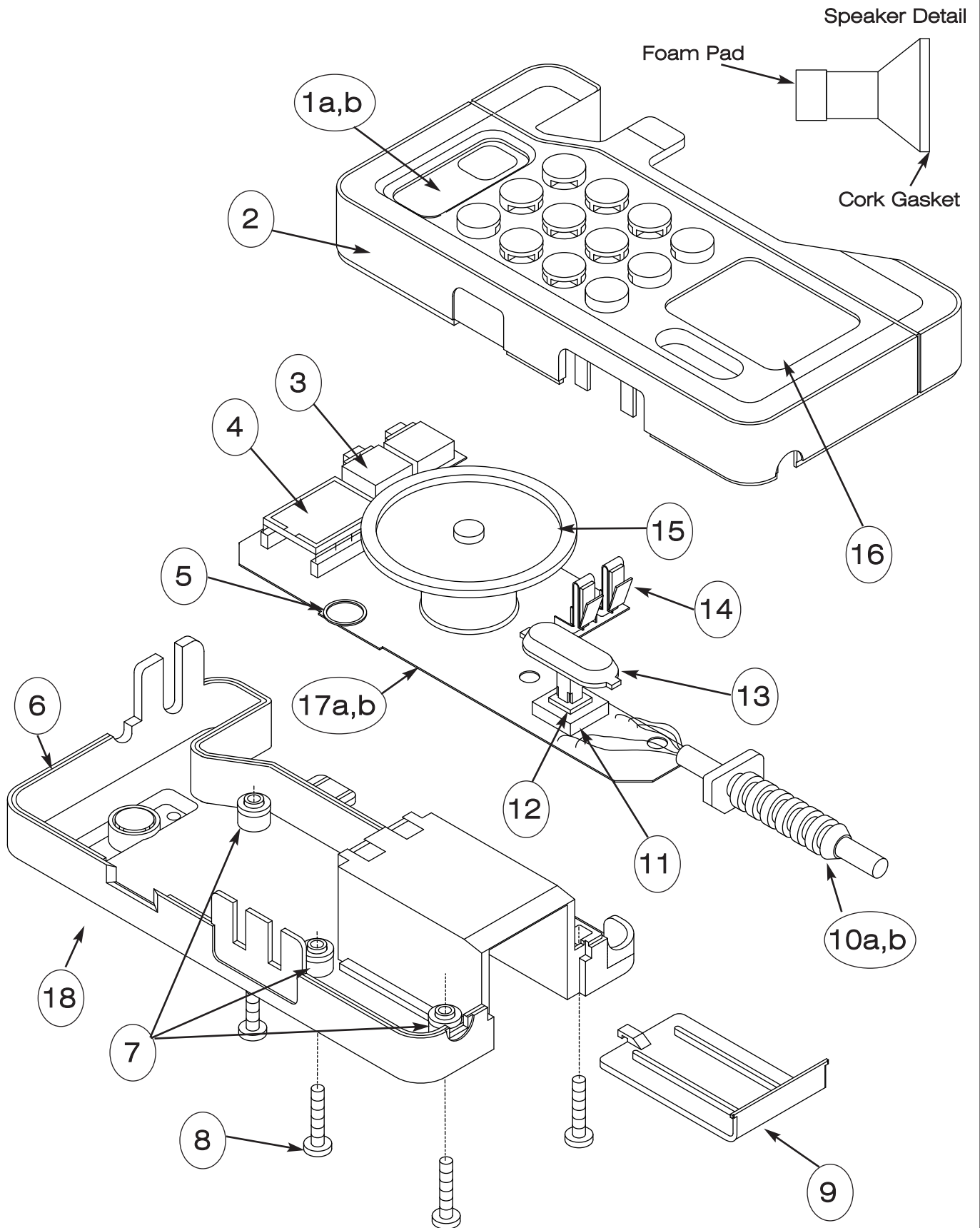

# Spare Parts List

Ref	Part Number	Description
1a	SP-6AH102	Window Label
1b	SP-734303	Window Label (LED Model)
2	SP-6AE102	Case Front
3	SP-726539	Headphone Socket
4	SP-CS194	LCD Display
5	SP-726487	Volume Control
6	SP-6AE103/1	Case Rear
7	SP-200-901	'O' Rings (3 per pack)
8	SP-726544	Case Screw (4 per pack)
9	SP-726486	Battery Cover
10a	SP-726222	Fixed Waterproof Probe and Cable 2MHz
10b	SP-726224	Fixed Waterproof Probe and Cable 3MHz
11	SP-B3W-4050	On/Off Switch
12	SP-6AE171	On/Off Button Spring
13	SP-726335B	On/Off Button
14	SP-726485	Battery Terminal (2 per pack)
15	SP-770312	MD Family Loudspeaker Assembly
16	SP-726309	D920 Label Set
17a	SP-726075	D920, D930 PCB
17b	SP-734055	D920, D930 PCB (LED Model)
18	SP-6AE107	Pocket Clip

### 10.3 MD-2, SD2, FD2, FD1, FD3, RD2 Parts List

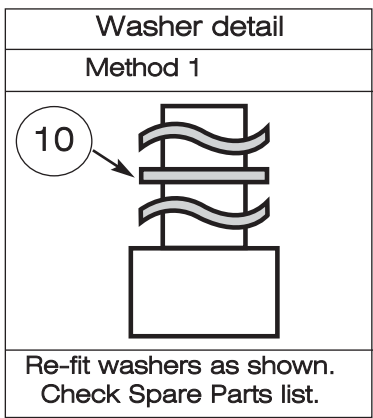
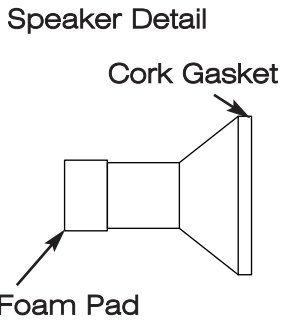
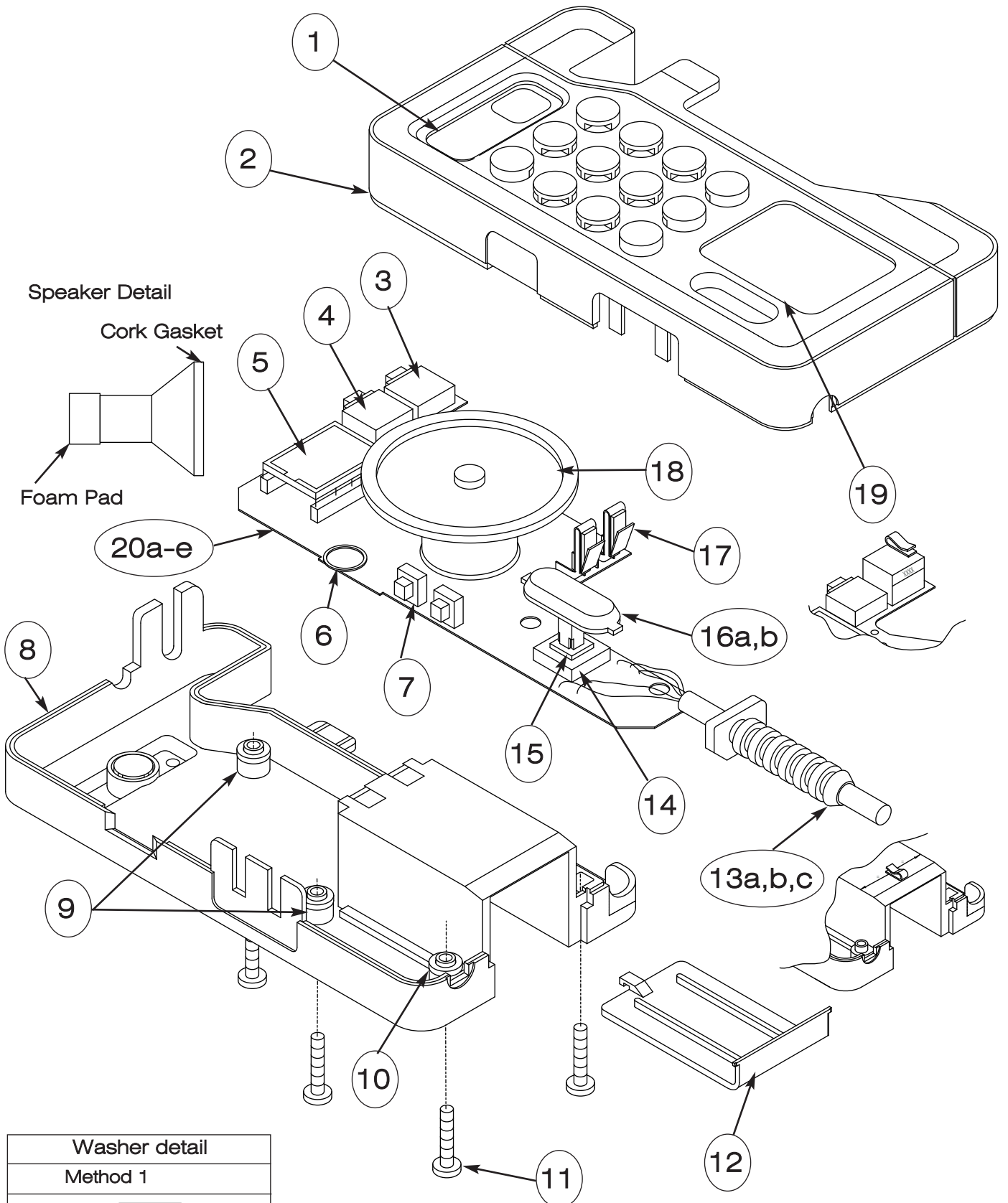

# Spare Parts List

Ref	Part Number	Description
1	SP-6AH103	Window Label
2	SP-6AE102/SE	Case Front
3	SP-MDJ8DM	Sub Miniature DIN Socket
4	SP-726539	Stereo Socket
5	SP-CS195	MD2 LCD Display
6	SP-726488	MD2 Volume Control
7	SP-B3F-3150	Function/Mode Switch
8	SP-6AE103/2/SE + 66EU102226	MD2 Case Rear
9	SP-200-901	'O' Rings (3 per pack)
10	SP-770314	Wavy & Flat Washer Kit
11	SP-726544	Case Screw (4 per pack)
12	SP-726486	Battery Cover
13a	SP-6AH104	Retractable Cable
13b	SP-726222	Fixed Waterproof Probe and Cable 2MHz
13c	SP-726224	Fixed Waterproof Probe and Cable 3MHz
14	SP-B3W-4050	On/Off Switch
15	SP-6AE171	On/Off Button Spring
16a	SP-6AE106	On/Off Button
16b	SP-726335B	FD1/FD3 On/Off Button
17	SP-726485	Battery Terminal (2 per pack)
18	SP-770312	MD Family Loudspeaker Assembly
19	SP-726303 SP-726304 SP-726306 SP-726435 SP-726314 SP-602305	MD2 Label Set SD2 Label Set FD2 Label Set FD3 Label Set FD1 Label Set RD2 Label Set
20a	SP-726054	MD2 PCB
20b	SP-726059	SD2 PCB
20c	SP-726064	FD2 PCB
20d	SP-726090	FD1/FD3 PCB
20e	SP-602078	RD2 PCB

## 10.4 Obstetric and Vascular Probe Parts List

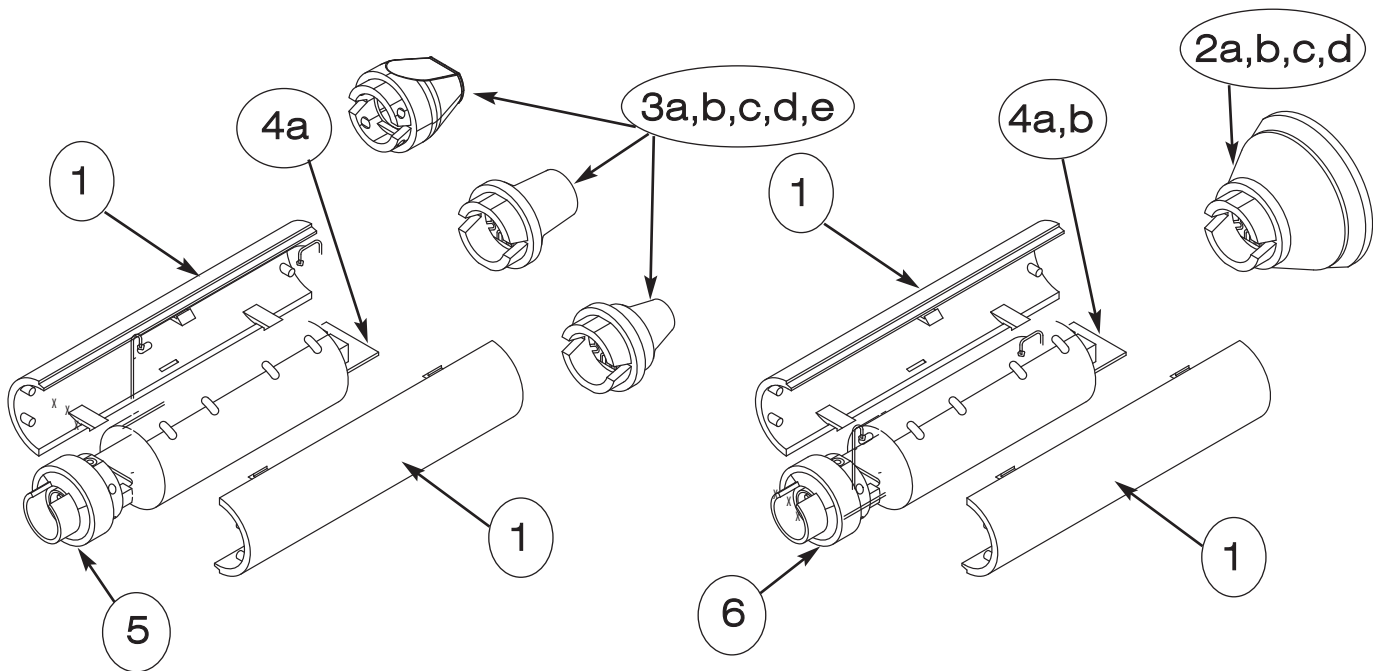

Ref	Part Number	Description
1	SP-6AE114	Probe Case Half (2 per pack)
2a	SP-HEAD-OP2HSG1	OP2 Head Assembly
2b	SP-HEAD-OP2HSG2	OP2 Head Assembly
2c	SP-HEAD-OP3HSG1	OP3 Head Assembly
2d	SP-HEAD-OP3HSG2	OP3 Head Assembly
3a	SP-HEAD-VP4HS	VP4 Head Assembly
3b	SP-HEAD-VP5HS	VP5 Head Assembly
3c	SP-HEAD-VP8HS	VP8 Head Assembly
3d	SP-HEAD-VP10HS	VP10 Head Assembly
3e	SP-HEAD-EZ8HS	Easy & Wide Beam Head Assembly
4a	SP-726535	Head Con VP, OPCE, B1, G1
4b	SP-M22-2530405	Head Con B2, G2
5	SP-734327	VP End Cap Assembly
6	SP-726564	OP End Cap Assembly

## 10.5 Fixed Waterproof Probes

D920, D930 and FD1 units have been fitted with two variants of fixed waterproof probe since 2008. The probes differ in the method of assembly and the parts used in their construction. There is no difference in performance as both types of probe use the same PCB.

The waterproof probe first fitted to the D920, D930 and FD1 is the **HSB** series of probes.

The probe currently fitted in manufacturing to the D920, D930, FD1 and the FD3 is the **SP-726222** and **SP-726224** series of probes.

The pictures below show how the different types of waterproof probes can be quickly identified without the need for disassembly.



OP#HSB# Series Probe - See Section 10.5a

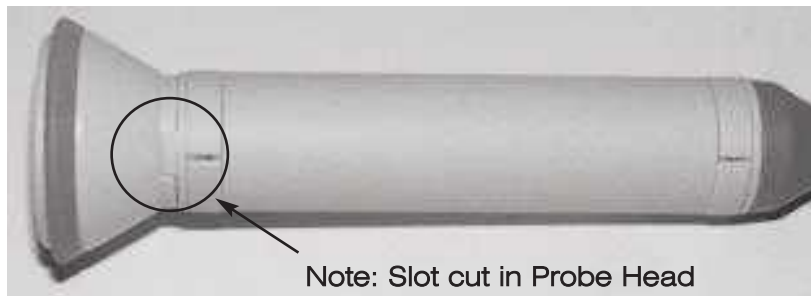

Note: Slot cut in Probe Head

SP-726222# Series Probe - See Section 10.5b

10.5a

D920, D930, FD1 HSB Series Probe Parts List

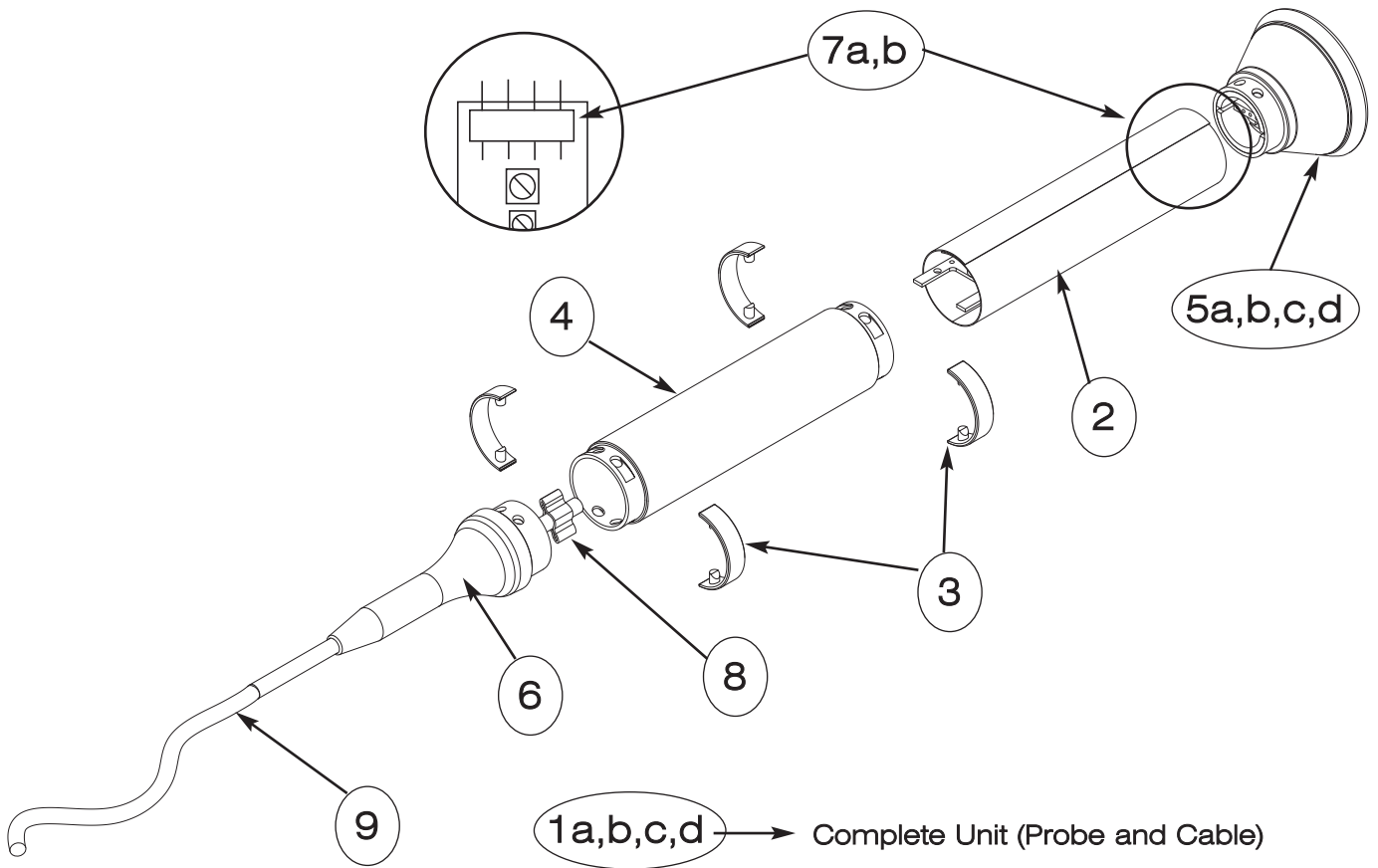

Ref	Part Number	Description
1a	SP-TDR - OP2HSB1	Fixed Waterproof Probe & Cable 2MHz
1b	SP-TDR - OP2HSB2	Fixed Waterproof Probe & Cable 2MHz
1c	SP-TDR - OP3HSB1	Fixed Waterproof Probe & Cable 3MHz
1d	SP-TDR - OP3HSB2	Fixed Waterproof Probe & Cable 3MHz
2	605059	Screen Assembly
3	SP-606318	Case Clip (4 per pack)
4	SP-606312	Case Moulding
5a	SP-HEAD - OP2HSB1	OP2 Head Assembly (Blue)
5b	SP-HEAD - OP2HSB2	OP2 Head Assembly (Blue)
5c	SP-HEAD - OP3HSB1	OP3 Head Assembly (Blue)
5d	SP-HEAD - OP3HSB2	OP3 Head Assembly (Blue)
6	SP-606320	Transducer Grommet Assy
7a	SP-M22-2530405	Head Con B2, G2
7b	SP-726535	Head Con VP, OPCE, B1, G1
8	SP-H0305	2-Ear Clamp
9	726381	Fixed Waterproof Probe Retractable Cable

10.5b

**D920, D930, FD1, FD3 Probe Parts List**

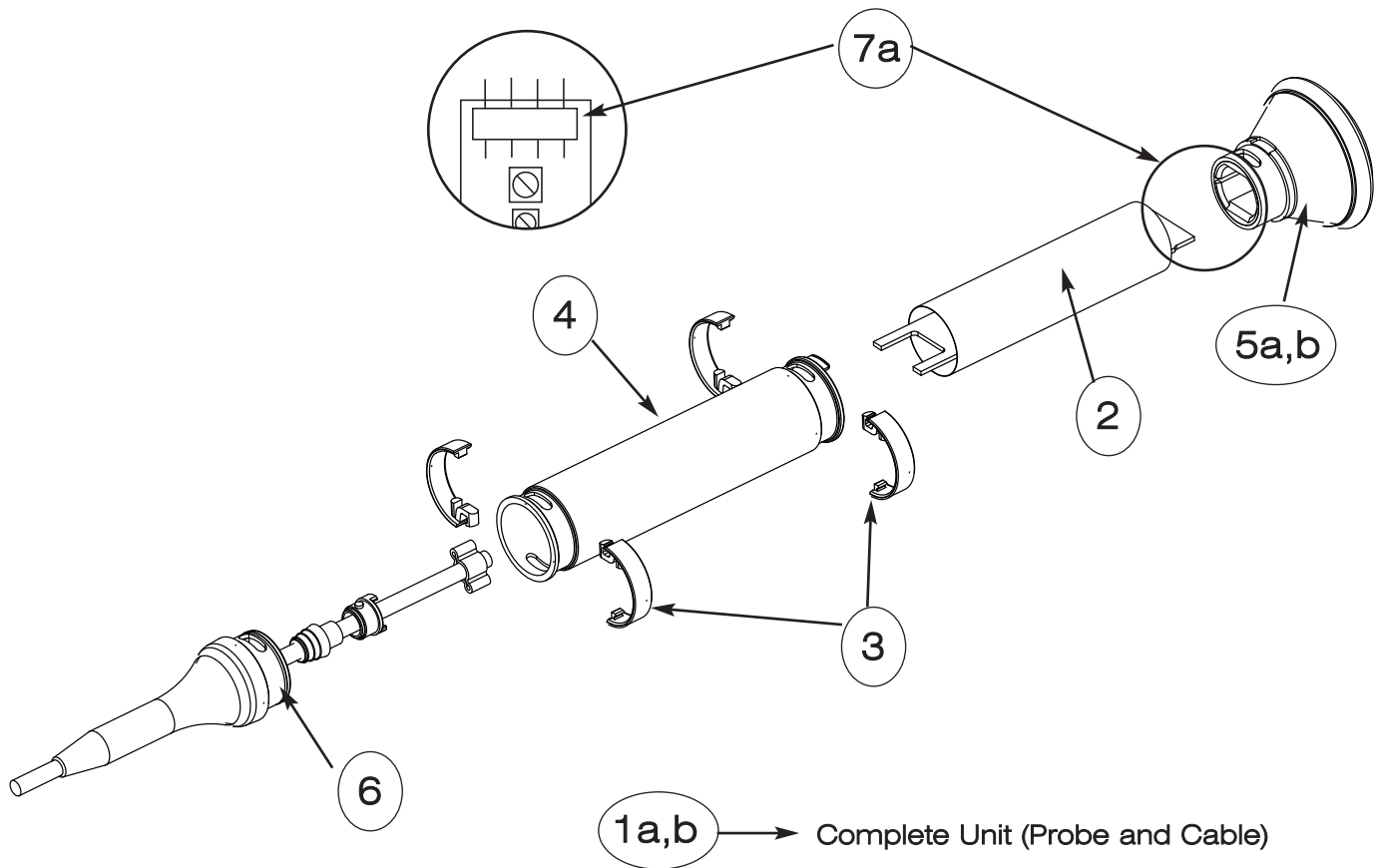

Ref	Part Number	Description
1a	SP-726222	FD1/D920 Spare Probe
1b	SP-726224	FD3/D930 Spare Probe
2	722065	Screen Assembly
3	SP-606331	Aqua Transducer Case Clip (4 per pack)
4	SP-606330	Aqua Transducer Case Moulding
5a	SP-726219	2MHz Head Assembly (Slotted)
5b	SP-726218	3MHz Head Assembly (Slotted)
6	SP-726245	Aqua Probe Cable Assembly
7a	SP-M22-2530405	Head Con B2, G2

N.B. For Wiring diagram, please refer to Appendix E.



## 10.6 PA8 Probe Parts List

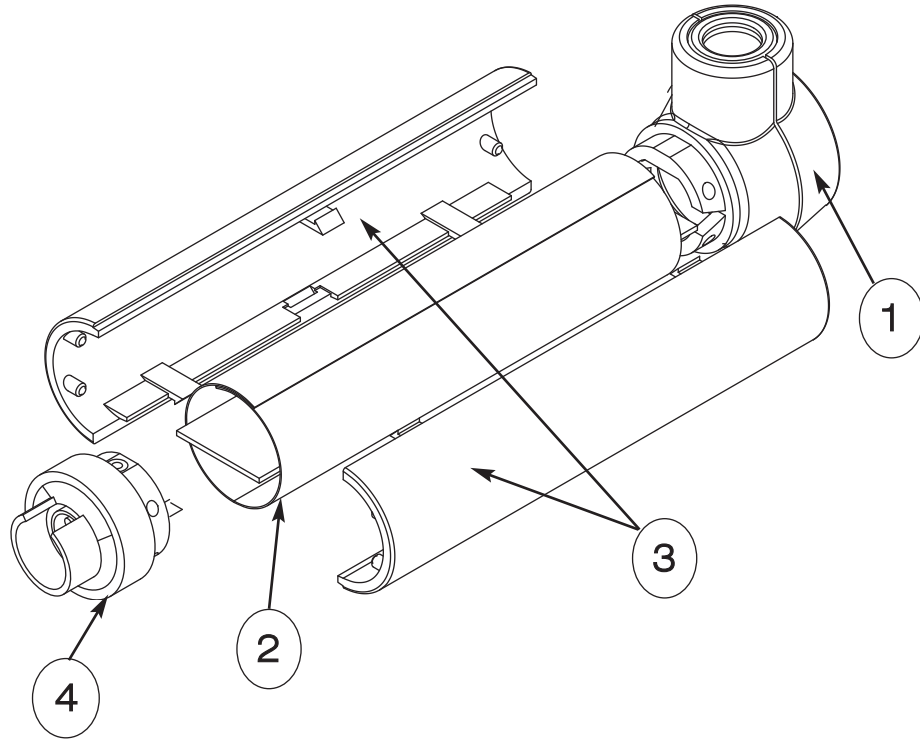

Ref	Part Number	Description
1	722061	PA8 Head Assembly
2	722065	Copper Screen Assembly
3	SP-6AE114	Probe Case Half (2 per pack)
4	SP-734327	VP End Cap Assembly

## 11. Ordering Information

To order spare parts and for price information, contact the Service Department at Huntleigh Healthcare Ltd. Before phoning, be sure to have the following information available to ensure that our service department personnel are able to correctly identify your requirements:

- Control unit model number.
- Control unit serial number.
- Probe frequency.
- Probe serial number.
- Part numbers of items required.

The service department direct line shown below offers a 24 hour service. During office hours, trained staff will be available to assist you. Outside office hours, an answering machine will allow you to leave a message.

### 11.1 Service Returns

If for any reason your Dopplex product is being returned, please observe the procedure below;

1. Decontaminate the unit and probe
2. Pack the unit inside suitable packing
3. Attach the decontamination certificate to the outside of the packing
4. Mark the package Service Department - (product model)

For further details refer to NHS Document HSG(93)26.

**Please note that waterproof models returned without observing the above procedure will be returned for decontamination.**

Huntleigh Healthcare Ltd - Diagnostic Products Division,  
Service Department,  
35, Portmanmoor Road,  
Cardiff, CF24 5HN, UK.  
Service Department Direct Line: (029) 20496793 (24 hr answer service)  
Fax: (029) 20492520

# Appendix A

## **Special Handling Procedures**

The PCB assemblies used in the control unit and probe contain electrostatic sensitive devices. These may be permanently damaged by electrostatic potentials encountered in routine handling of the assemblies during servicing.

We therefore recommend that all servicing be carried out in a specialised handling area (SHA) as defined by CECC00015 (published by CENELEC) to avoid damage to the assemblies.

## **Recommended Soldering Equipment for Rework**

The following should be used for all soldering operations carried out on any Dopplex product in servicing:

Soldering Iron: 'Mini' type iron, temperature controlled to 375°C with fine tip (typically 0.8mm(1/32")) earth bonded. e.g.Weller EC3100D-ESP.

Solder: SN62 type solder with multi cored flux type RA conforming to QQ-S-571e (US federal specification). e.g.Multicore 'smart wire'.

If further information is required, please contact Huntleigh Healthcare Ltd



# Appendix C

## **Recommended Recorder Specifications**

Vertical axis resolution:	6 dots/mm typical (if digital).
Chart Speed:	10-25mm/sec typical.
Minimum number of channels:	2.
Full scale span:	50mm or greater.
Input ranges:	20mV/mm and 50mV/mm.
Input impedance:	>50k $\Omega$
Bandwidth:	DC to 25Hz minimum.

## Appendix D

### Test Equipment Specification

<b>Synthesised Signal Generator</b>	
Frequency Range	1-20MHz
Frequency Resolution	10Hz or better
Residual FM (0.03 to 20KHz)	<8Hz
SSB Phase Noise	-136dBc typical
Output Level Range	-100 to +13dBm
Output Level Resolution	0.1dB or better
Output Impedence	50 $\Omega$
<b>Frequency Counter</b>	
Frequency Range	5Hz - 20MHz
Resolution	1 Hz
Digits	7
Input Range	15mV - 10V rms
Input Impedence (typical)	1M $\Omega$ with 30pF parallel
Frequency Accuracy	+/- 0.1%
<b>DMM</b>	
Current Range	0 - 100mA min
Resolution	1mA min
Digits	3 min
<b>Power Supply</b>	
Voltage	5Vdc
Output Current Rating	100mA min
Hum + Noise	-130dBV or less
Overcurrent Protection	Yes (can be set to 100mA)

# Appendix E

## D920, D930, FD1, FD3 Probe Cable Wiring Details

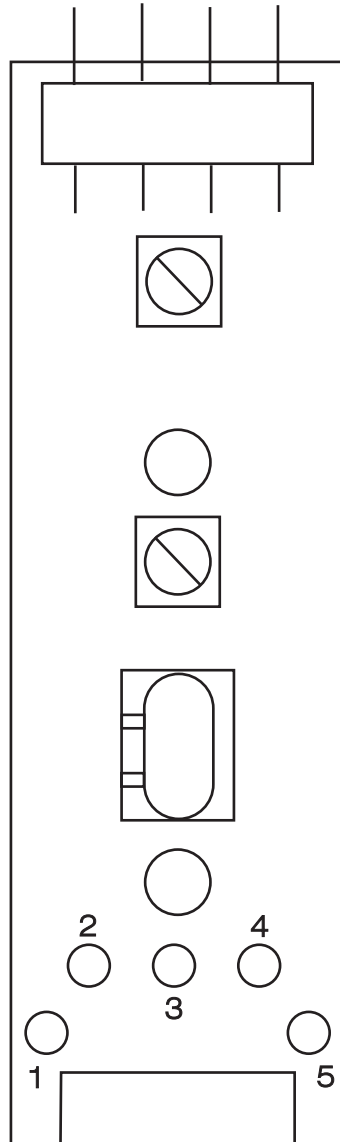

1	2	3	4	5
Screen	White	Black	Red	Yellow
Screen	Violet	Pink	Orange	Turquoise
Screen	White	Black	Red	Violet

Several variations of cable colours are used as shown.

## Appendix F

### Waveform Output Connector Details - RD2 / MD2

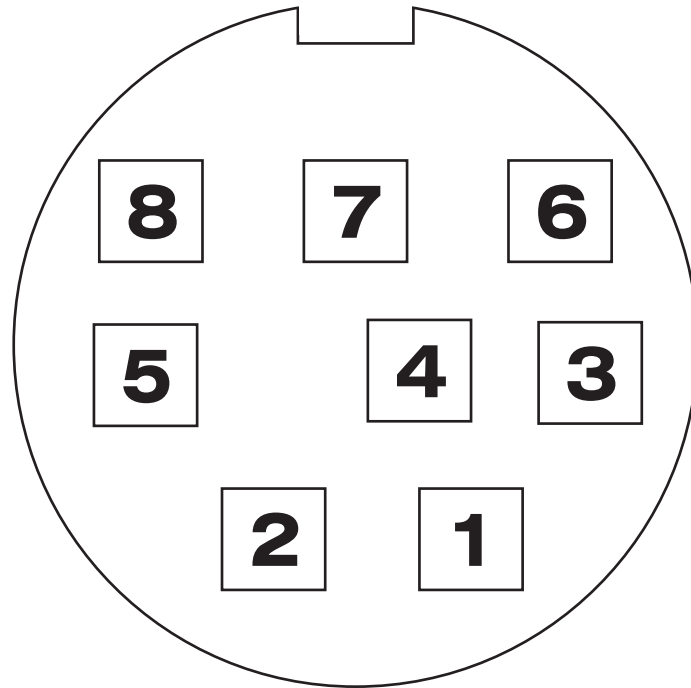

Pin	Connection
1	RS232 - TX
2	RS232 - RX
3	GROUND
4	WAVEFORM
5	RS232 - BUSY
6	5V
7	WAVEFORM
8	RS232 - ENABLE



# Appendix G

## Trace Examples

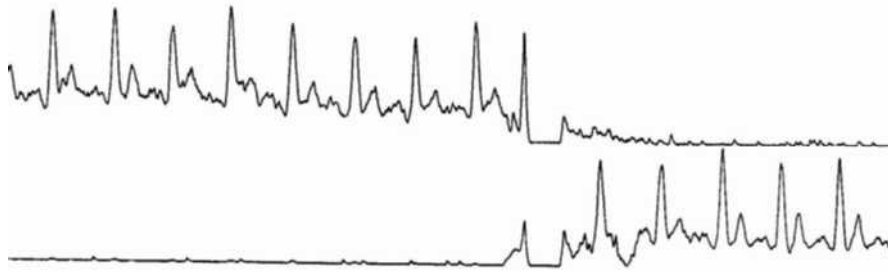

10mm/sec  
50mV/mm

4 MHz

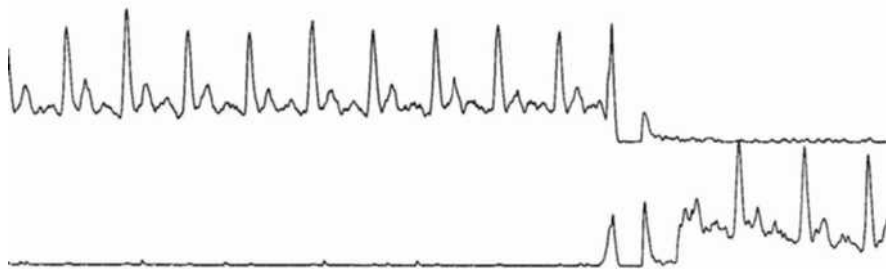

10mm/sec  
50mV/mm

5 MHz

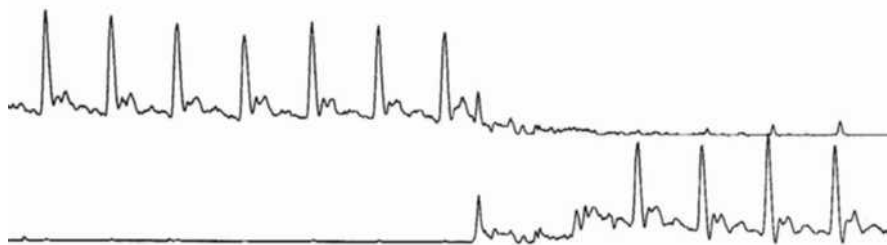

10mm/sec  
50mV/mm

8 MHz

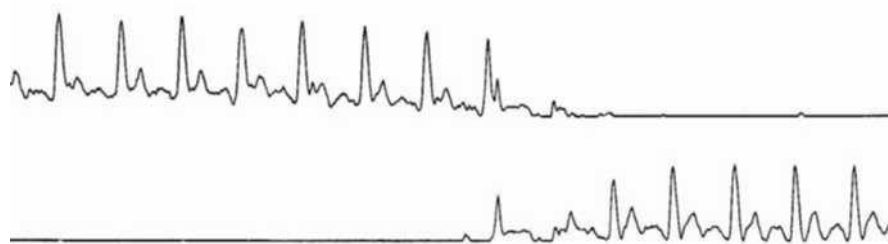

10mm/sec  
50mV/mm

10 MHz



## Appendix H

### Electromagnetic Compatibility

Make sure the environment in which dopplex Dopplers are installed is not subject to strong sources of electromagnetic interference (e.g. radio transmitters, mobile phones).

This equipment generates and uses radio frequency energy. If not installed and used properly, in strict accordance with the manufacturer's instructions, it may cause or be subject to interference. Type-tested in a fully configured system, complies with EN60601-1-2, the standard intended to provide reasonable protection against such interference. Whether the equipment causes interference may be determined by turning the equipment off and on. If it does cause or is affected by interference, one or more of the following measures may correct the interference:

- Reorienting the equipment
- Relocating the equipment with respect to the source of interference
- Moving the equipment away from the device with which it is interfering
- Plugging the equipment into a different outlet so that the devices are on different branch circuits

	<b>WARNING:</b> <i>The use of accessories, transducers and cables other than those specified, with the exception of transducers and cables sold by the manufacturer of the dopplex Dopplers as replacement parts for internal components, may result in increased emissions or decreased immunity of the dopplex Dopplers.</i>
	<b>WARNING:</b> <i>Dopplex Dopplers should not be used adjacent to or stacked with other equipment and that if adjacent or stacked use is necessary, dopplex Dopplers should be observed to verify normal operation in the configuration in which it will be used .</i>

<b>Guidance and Manufacturer's declaration - electromagnetic emissions</b>		
Dopplex Dopplers are intended for use in the electromagnetic environment specified below. The customer or the user of the dopplex Dopplers should assure that they are used in such an environment.		
<b>Emissions Test</b>	<b>Compliance</b>	<b>Electromagnetic Environment - Guidance</b>
RF emissions CISPR 11	Group 1	Dopplex Dopplers use RF energy only for its internal function. Therefore, its RF emissions are very low and are not likely to cause any interference in nearby electronic equipment.
RF emissions CISPR 11	Class B	Dopplex Dopplers are suitable for use in all establishments, including domestic establishments and those directly connected to the public low-voltage power supply network that supplies buildings used for domestic purposes.
Harmonic emissions IEC 61000-3-2	N/A	
Voltage fluctuations / flicker emissions IEC 61000-3-3	N/A	

**Guidance and Manufacturer's declaration - electromagnetic immunity**

Dopplex Dopplers are intended for use in the electromagnetic environment specified below. The customer or the user of the Dopplex Dopplers should assure that they are used in such an environment.

<b>Immunity Test</b>	<b>IEC 60601 Test level</b>	<b>Compliance level</b>	<b>Electromagnetic Environment - Guidance</b>
Electrostatic discharge (ESD) IEC 61000-4-2	± 6 kV contact ± 8 kV air	6kV 8kV	Floors should be wood, concrete or ceramic tile. If floors are covered with synthetic material, the relative humidity should be at least 30 %.
Electrical fast transient/burst IEC 61000-4-4	± 2 kV for power supply lines ± 1 kV for input/output lines	N/A	Mains power quality should be that of a typical commercial or hospital environment.
Surge IEC 61000-4-5	± 1 kV line(s) to line(s) ± 2 kV line(s) to earth	N/A	N/A
Voltage dips, short interruptions and voltage variations on power supply input lines IEC 61000-4-11	<5 % $U_T$ (>95 % dip in $U_T$ ) for 0,5 cycle  40 % $U_T$ (60 % dip in $U_T$ ) for 5 cycles  70 % $U_T$ (30 % dip in $U_T$ ) for 25 cycles  <5 % $U_T$ (>95 % dip in $U_T$ ) for 5 s	N/A	N/A
Power frequency (50/60 Hz) magnetic field IEC 61000-4-8	3A/m	3A/m	Power frequency magnetic fields should be at levels characteristic of a typical location in a typical commercial or hospital environment.
NOTE $U_T$ is the a.c. mains voltage prior to application of the test level.			

Guidance and Manufacturer's declaration - electromagnetic immunity			
Dopplex Dopplers are intended for use in the electromagnetic environment specified below. The customer or the user of the Dopplex Dopplers should assure that they are used in such an environment.			
Immunity Test	IEC 60601 Test level	Compliance level	Electromagnetic Environment - Guidance
			Portable and mobile RF communications equipment should be used no closer to any part of the dopplex Dopplers, including cables, than the recommended separation distance calculated from the equation applicable to the frequency of the transmitter.
Conducted RF IEC 61000-4-6	3 Vrms 150kHz to 80MHz	3V	$d = 1.2 \sqrt{P}$
Radiated RF IEC 61000-4-3	3 V/m 80MHz to 2.5GHz	3V/m	$d = 1.2 \sqrt{P}$ 80MHz to 800MHz $d = 2.3 \sqrt{P}$ 800MHz to 2.5GHz
			<p>where <math>P</math> is the maximum output power rating of the transmitter in watts (W) according to the transmitter manufacturer and <math>d</math> is the recommended separation distance in metres (m).</p> <p>Field strengths from fixed RF transmitters, as determined by an electromagnetic site survey, <sup>a</sup> should be less than the compliance level in each frequency range <sup>b</sup>.</p> <p>Interference may occur in the vicinity of the equipment marked with the following symbol:</p> 
<p>NOTE 1 At 80MHz and 800MHz, the higher frequency range applies.</p> <p>NOTE 2 These guidelines may not apply in all situations. Electromagnetic propagation is affected by absorption and reflection from structures, objects and people.</p>			
<p><sup>a</sup> Field strengths from fixed transmitters, such as base stations for radio (cellular/cordless) telephones and land mobile radios, amateur radio, AM and FM radio broadcast and TV broadcast cannot be predicted theoretically with accuracy. To assess the electromagnetic environment due to fixed RF transmitters, an electromagnetic site survey should be considered. If the measured field strength in the location in which the dopplex Dopplers are used exceeds the applicable RF compliance level above, the dopplex Dopplers should be observed to verify normal operation. If abnormal performance is observed, additional measures may be necessary, such as re-orienting or relocating the dopplex Dopplers.</p> <p><sup>b</sup> Over the frequency range 150kHz to 80kHz, field strengths should be less than 3V/m.</p>			

### Recommended separation distances between portable and mobile RF communications equipment and the Dopplex Dopplers

Dopplex Dopplers are intended for use in an electromagnetic environment in which radiated RF disturbances are controlled. the customer or user of the Dopplex Dopplers can help prevent electromagnetic interference by maintaining a minimum distance between portable and mobile RF communications equipment (transmitters) and the Dopplex Dopplers as recommended below, according to the maximum output power of the communications equipment.

Rated maximum output power of transmitter  W	Separation distance according to frequency of transmitter m		
	150kHz to 80MHz $d = 1.2 \sqrt{P}$	80MHz to 800MHz $d = 1.2 \sqrt{P}$	800MHz to 2.5GHz $d = 2.3 \sqrt{P}$
0.01	0.12	0.12	0.23
0.1	0.38	0.38	0.73
1	1.2	1.2	2.3
10	3.8	3.8	7.3
100	12	12	23

For transmitters rated at a maximum output power not listed above, the recommended separation distance  $d$  in metres (m) can be estimated using the equation applicable to the frequency of the transmitter, where  $P$  is the maximum output power rating of the transmitter in watts (W) according to the transmitter manufacturer.

NOTE 1 At 80MHz and 800MHz, the separation distance for the higher frequency range applies.

NOTE 2 These guidelines may not apply in all situations. Electromagnetic propagation is affected by absorption and reflection from structures, objects and people.

# HUNTLEIGH ...with people in mind

Huntleigh Healthcare Ltd. - Diagnostic Products Division  
35 Portmanmoor Road, Cardiff, CF24 5HN, United Kingdom  
T: +44 (0)29 20485885 F: +44 (0)29 20492520  
E: sales@huntleigh-diagnostics.co.uk  
W: www.huntleigh-diagnostics.com

## DISTRIBUTED IN GERMANY BY:

HNE Huntleigh Nesbit Evans Healthcare GmbH  
Industriering Ost 66, 47906 Kempen  
T: +49 (0) 2152-5511-11 F: +49 (0) 2152-5511-20  
E: Verkauf@huntleigh.de

## DISTRIBUTED IN USA BY:

ArjoHuntleigh  
2349 West Lake Street , Addison, Illinois 60101  
T: 800-323-1245 F: 630-925-7969  
www.ArjoHuntleigh.com



Registered No: 942245 England & Wales. Registered Office: ArjoHuntleigh House,  
Houghton Hall Business Park, Houghton Regis, Bedfordshire, LU5 5XF

© Huntleigh Healthcare Limited 2004-2009

AN ARJOHUNTLEIGH COMPANY, MEMBER OF THE GETINGE GROUP

® and ™ are trademarks of Huntleigh Technology Limited  
As our policy is one of continuous improvement, we reserve the right to modify designs without prior notice.